

SNH & NH

1" Wide



- Two Terminals, One End (type SNH)
- One Terminal, Each End (type NH)
- 8 - 53-7/8" Lengths
- 250 - 1,500 Watts
- 120 and 240 Volt
- 7 - 24 W/in²



Dimensions (type NH)

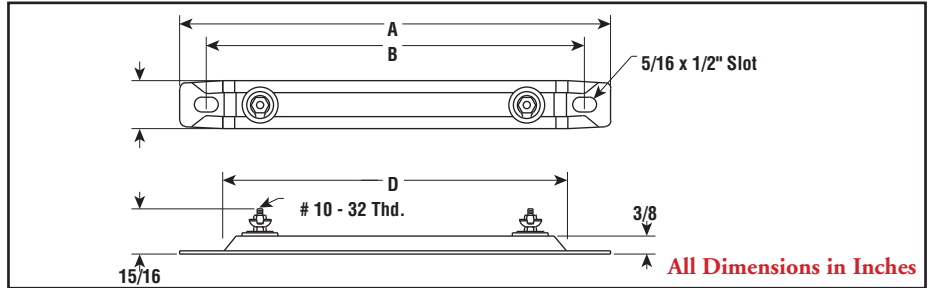

Dimensions (type SNH)

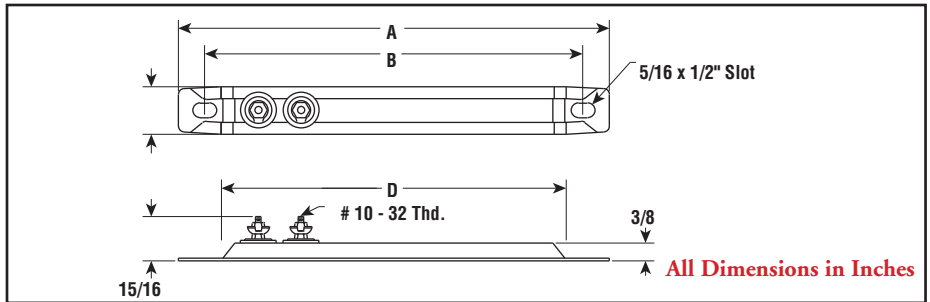

Applications

Strip heaters are used for heat transfer by conduction or convection to heat liquids, air, gases and surfaces.