

Chromalox®

Installation and RENEWAL PARTS IDENTIFICATION Type LUH Horizontal Unit Heater

SERVICE REFERENCE

| | | | |
|--------------------------------------|--|----------------|--|
| DIVISION 4 | | SECTION LUH | |
| SALES REFERENCE (Supersedes PF479-5) | | PF479-6 | |
| | | 161-303474-001 | |
| DATE | | JANUARY, 2003 | |



Specifications — Table 1

| Model | Electrical Data (60 Hz) | | | | BTU | Dimensions (In.) | | | Standard Contactor Rating (Qty.) |
|---------------|-------------------------|---------------|-------|--------|---------|------------------|--------|--------|----------------------------------|
| | Volts | Watts | Phase | Amps | | Height | Width | Depth | |
| LUH-D-02-81 | 208 | 2,667 | 1 | 12.8 | 8,850 | 16 | 13-1/8 | 8-7/8 | 30A (1) |
| LUH-D-02-21 | 208/240 | 2,000/2,667 | 1 | 11.1 * | | | | | 30A (1) |
| LUH-D-02-71 | 277 | 2,667 | 1 | 9.6 | | | | | 30A (1) |
| LUH-D-04-81 † | 208 | 4,000 | 1 | 19.2 | 13,661 | 16 | 13-1/8 | 8-7/8 | 30A (1) |
| LUH-D-04-83 † | | | 3 | 11.2 | | | | | 30A (1) |
| LUH-D-04-21 † | 208/240 | 3,000/4,000 | 1 | 16.7 * | | | | | 30A (1) |
| LUH-D-04-23 † | | | 3 | 9.6 * | 30A (1) | | | | |
| LUH-D-04-71 | 277 | 4,000 | 1 | 14.5 | 17,076 | 16 | 13-1/8 | 8-7/8 | 30A (1) |
| LUH-D-04-43 | 480 | 4,000 | 3 | 4.8 | | | | | 30A (1) |
| LUH-D-05-81 † | 208 | 5,000 | 1 | 24.0 | | | | | 30A (1) |
| LUH-D-05-83 † | | | 3 | 13.8 | 30A (1) | | | | |
| LUH-D-05-21 † | 208/240 | 3,750/5,000 | 1 | 20.8 * | 25,598 | 16 | 13-1/8 | 8-7/8 | 30A (1) |
| LUH-D-05-23 † | | | 3 | 12.1 * | | | | | 30A (1) |
| LUH-D-05-71 | 277 | 5,000 | 1 | 18.2 | | | | | 30A (1) |
| LUH-D-05-43 | 480 | 5,000 | 3 | 6.0 | 30A (1) | | | | |
| LUH-D-07-81 † | 208 | 7,500 | 1 | 36.1 | 34,130 | 20-1/2 | 17-1/4 | 11-1/2 | 50A (1) |
| LUH-D-07-83 † | | | 3 | 20.9 | | | | | 30A (1) |
| LUH-D-07-21 † | 208/240 | 5,625/7,500 | 1 | 31.1 * | | | | | 30A (1) |
| LUH-D-07-23 † | | | 3 | 18.1 * | 30A (1) | | | | |
| LUH-D-07-71 | 277 | 7,500 | 1 | 27.2 | 30A (1) | | | | |
| LUH-D-07-43 | 480 | 7,500 | 3 | 9.0 | 30A (1) | | | | |
| LUH-D-10-81 † | 208 | 10,000 | 1 | 48.0 | 42,663 | 20-1/2 | 17-1/4 | 11-1/2 | 50A (1) |
| LUH-D-10-83 † | | | 3 | 27.8 | | | | | 30A (1) |
| LUH-D-10-21 † | 208/240 | 7,500/10,000 | 1 | 41.7 * | | | | | 30A (1) |
| LUH-D-10-23 † | | | 3 | 24.0 * | 30A (1) | | | | |
| LUH-D-10-43 | 480 | 10,000 | 3 | 12.0 | 30A (1) | | | | |
| LUH-D-12-83 | 208 | 12,500 | 3 | 34.8 | 51,195 | 20-1/2 | 17-1/4 | 11-1/2 | 50A (1) |
| LUH-D-12-23 | 208/240 | 9,375/12,500 | 3 | 30.1 * | | | | | 50A (1) |
| LUH-D-12-43 | 480 | 12,500 | 3 | 15.1 | | | | | 30A (1) |
| LUH-D-15-83 | 208 | 15,000 | 3 | 41.8 | 68,460 | 24 | 20-1/8 | 11-1/2 | 50A (1) |
| LUH-D-15-23 | 208/240 | 11,250/15,000 | 3 | 36.2 * | | | | | 50A (1) |
| LUH-D-15-43 | 480 | 15,000 | 3 | 18.1 | | | | | 30A (1) |
| LUH-D-20-23 | 208/240 | 15,000/20,000 | 3 | 48.0 * | 85,525 | 24 | 20-1/8 | 11-1/2 | 50A (1) |
| LUH-D-20-43 | 480 | 20,000 | 3 | 24.0 | | | | | 50A (2) |
| LUH-D-25-43 | 480 | 25,000 | 3 | 30.0 | | | | | 30A (2) |
| LUH-D-30-83 | 208 | 30,000 | 3 | 83.4 | 102,390 | 24 | 20-1/8 | 17-1/4 | 50A (2) |
| LUH-D-30-23 | 208/240 | 22,500/30,000 | 3 | 72.2 * | | | | | 50A (2) |
| LUH-D-30-43 | 480 | 30,000 | 3 | 36.1 | | | | | 30A (2) |
| LUH-D-35-23 | 208/240 | 26,250/35,000 | 3 | 84.3 * | 119,455 | 24 | 20-1/8 | 17-1/4 | 50A (2) |
| LUH-D-35-43 | 480 | 35,000 | 3 | 42.1 | | | | | 30A (2) |
| LUH-D-40-23 | 208/240 | 30,000/40,000 | 3 | 96.0 * | | | | | 50A (2) |
| LUH-D-40-43 | 480 | 40,000 | 3 | 48.0 | 136,520 | 24 | 20-1/8 | 17-1/4 | 30A (2) |
| LUH-D-45-43 | 480 | 45,000 | 3 | 54.1 | | | | | 30A (2) |

*Note: 208V amperage is 86% of 240V value.

† These models can be field changed from single phase to three phase or three phase to single phase.

IMPORTANT

Failure to understand and follow these installation instructions and the “WARNING” notes therein may result in serious personal injury from electrical shock, or from the heater failing due to faulty installation.

⚠ WARNING

FIRE/EXPLOSION HAZARD. This heater is not intended for use in hazardous atmospheres where flammable vapors, gases, liquids or other combustible atmospheres are present as defined in the National Electrical Code. Failure to comply can result in personal injury, explosion or fire. For these applications see PDS CXH-A-EP (PF490).

⚠ WARNING

Users should install adequate back-up controls and safety devices with their electric heating equipment. Where the consequences of failure may be severe, back-up controls are essential.

Do not mount mercury type thermostat directly on unit. Vibration could cause heater to malfunction.

The heater must be mounted at least 7' above the floor to prevent accidental contact with the heating elements or fan blade which could cause injury.

Keep at least 5' clearance in front of the heater. Refer to Table 2 for side, top and back clearance requirements.

The ceiling mounting structure and the anchoring provisions must be of sufficient strength to support the combined weight of the heater and mounting bracket. (Refer to Table 3 for weights of heater and bracket.)

The wall or mounting surface, and the anchoring provisions must be capable of supporting the combined weight of the heater and mounting brackets cantilevered from the mounting surface. (Refer to Table 3 for weights of heater and brackets and for cantilevered force expressed in foot-pounds.)

Fan blade rotation must be checked. If airflow is not moving out through the louvers, interchange any two of the three customer power leads on three-phase units only.

GENERAL

Heater Location Instructions:

Arrange units so their discharge air streams:

- A. are subjected to a minimum of interference from columns, machinery and partitions.
- B. wipe exposed walls without blowing directly at them.
- C. are directed away from room occupants in comfort heating.
- D. are directed along the windward side when installed in a building exposed to a prevailing wind.

Locate thermostat on interior partition walls or posts away from cold drafts, internal heat sources and away from heater discharge air streams.

Small rooms can be heated by one unit heater. Where two walls are exposed, the heater should be mounted as shown in Figure 1.

Large rooms require multi-unit installation. Number and capacity of units will be determined by volume of building and square feet of floor area to be heated. Arrange units to provide perimeter air circulation where each unit supports the air stream from another.

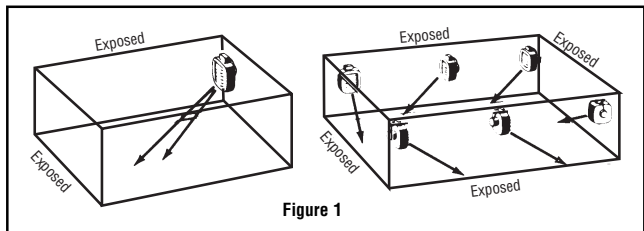

INSTALLATION

⚠ WARNING

Please read all of the following instructions: Failure to observe these precautions could result in personal injury or equipment damage.

1. The heater must be mounted at least 7' above the floor to prevent accidental contact with the heating elements or fan blade which could cause injury.
2. Keep at least 5' clearance in front of heater. Refer to Table 2 for side, top and back clearance requirements.

Clearance Requirements — Table 2

| Basic Model | Mounting Limitations (In.) | | |
|-----------------------|----------------------------|--------------|----------------|
| | Back to Wall | Side to Wall | Top to Ceiling |
| LUH-02 through LUH-05 | 6 | 6 | 4 |
| LUH-07 through LUH-15 | 6 | 6 | 6 |
| LUH-20 and LUH-25 | 6 | 6 | 6 |
| LUH-30 through LUH-45 | 6 | 6 | 6 |

3. The ceiling mounting structure and the anchoring provisions must be sufficient to support the combined weight of the heater and mounting bracket. (Refer to Table 3 for weights of heater and bracket.)
4. The wall or mounting surface and the anchoring provisions must be capable of supporting the combined weight of the heater and mounting brackets cantilevered from the mounting surface. (Refer to Table 3 for weights of heater and brackets and for cantilevered force expressed in foot-pounds.)

The heater may be mounted either on the ceiling or on the wall as follows:

- A. **CEILING.** The ceiling mounting bracket is fastened to the top of the heater using the four bolts supplied with the mounting bracket. The bracket is then mounted to the ceiling using a 5/8" bolt (supplied by others).

CEILING (Alternate)

1. The heater can be rod mounted to the ceiling by installing four threaded mounting rods in the threaded holes located on the top of the heater as shown in Figure 2. (Refer to Table 4 for mounting rod thread size.)
2. Securely attach the four mounting rods to the ceiling. (Refer to Table 2 for wall and ceiling clearances, and Figure 3 for mounting spacing specifications).

- B. **WALL.** Wall mounting kits include both a ceiling mounting bracket and a wall mounting bracket. First, attach the ceiling mounting bracket to the heater as described in step 4A. Then attach the wall mounting bracket to the wall using four 3/8" bolts (supplied by others). Attach the ceiling mounting bracket on the heater to the wall mounting bracket using the 5/8" bolt provided.

The heater may be rotated to discharge in the desired direction. Open and adjust louvers to desired position. See Figure 4 and 5 for additional mounting details.

Heater & Bracket Weights Combined — Table 3

| Heater Model | Weight (Lbs.) Ceiling Weight | Weight (Lbs.) Heater and Brackets Wall | |
|-----------------------|------------------------------|--|----------|
| | | Weight | Ft./Lbs. |
| LUH-02 through LUH-05 | 33-3/4 | 38-1/4 | 48 |
| LUH-07 through LUH-15 | 55 | 67-1/4 | 112 |
| LUH-20 through LUH-25 | 78 | 90-1/4 | 150 |
| LUH-30 through LUH-45 | 117 | 141-1/4 | 400 |

INSTALLATION

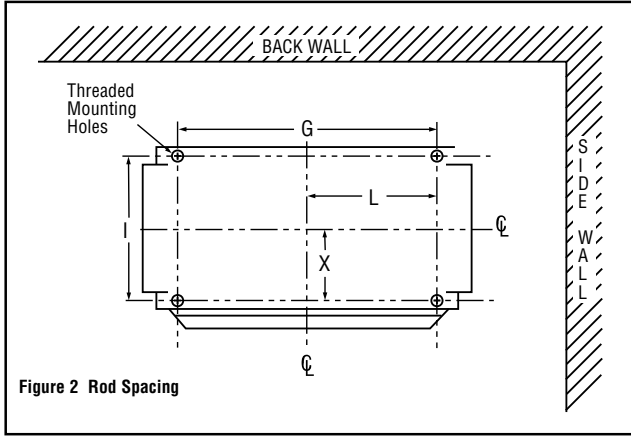
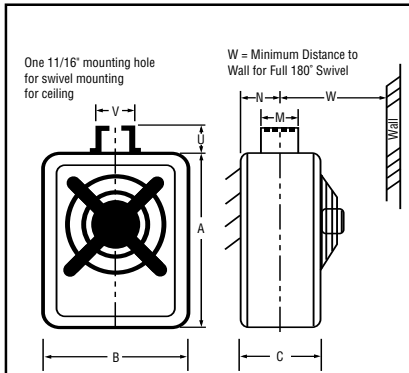
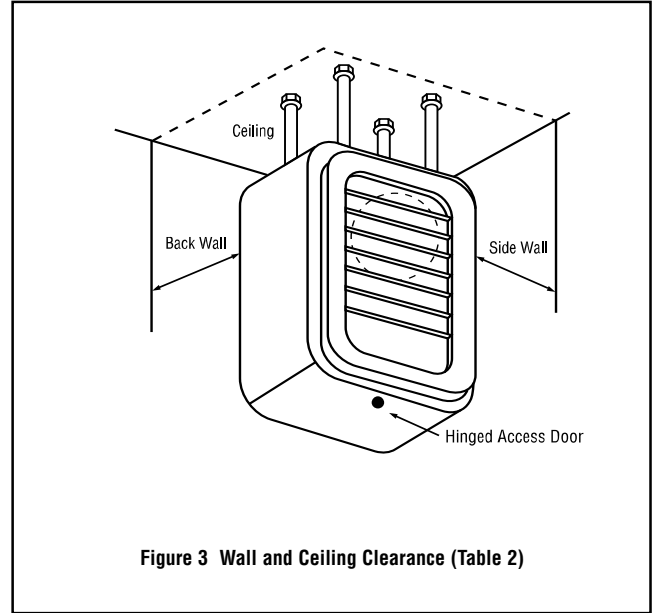
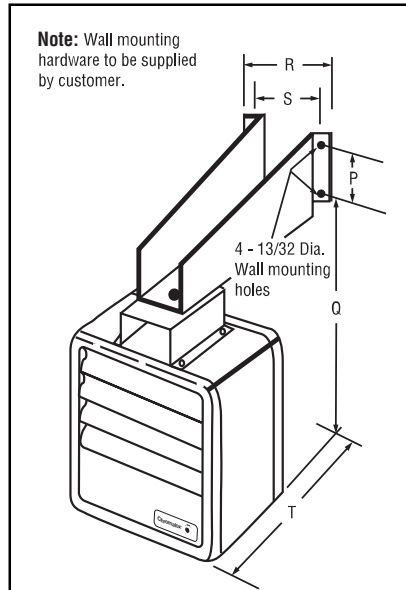

Table 4 — Rod Thread Type and Spacing Dimensions (In.) for Horizontal Discharge

| Unit | Rod Thread Type | Dimensions (In.) | | | |
|--------------|-----------------|------------------|-------|-------|-------|
| | | I | G | L | X |
| 2 - 5kW | 5/16 - 18 | 4-1/2 | 5-1/2 | 2-3/4 | 2-1/4 |
| 7-1/2 - 15kW | 3/8 - 16 | 6-1/4 | 8-1/4 | 4-1/8 | 3-1/8 |
| 20 - 25kW | 3/8 - 16 | 6-1/4 | 8-1/4 | 4-1/8 | 3-1/8 |
| 30 - 45kW | 3/8 - 16 | 11-3/4 | 8-1/4 | 4-1/8 | 5-7/8 |



| Bracket Model No. | Dimensions (In.) | | | | | | | Wt. (Lbs.) | Use With | |
|-------------------|------------------|--------|--------|--------|--------|---|-------|------------|----------|--------------------|
| | A | B | C | M | N | U | V | | | |
| WUH-04A | 16 | 13-1/8 | 8-7/8 | 6 | 4-7/16 | 4 | 4-1/2 | 10-1/2 | 3 | LUH-02, 04, 05 |
| WUH-05 | 20-1/2 | 17-1/4 | 11-1/2 | 8 | 6-1/4 | 6 | 7-1/4 | 16 | 5-1/2 | LUH-07, 10, 12, 15 |
| WUH-05 | 24 | 20-1/8 | 11-1/2 | 8 | 6-1/4 | 6 | 7-1/4 | 16 | 5-1/2 | LUH-20, 25 |
| WUH-06 | 24 | 20-1/8 | 17 | 13-3/4 | 10 | 6 | 7-1/4 | 21 | 11 | LUH-30, 35, 40, 45 |



| Bracket Model Number | Dimensions - (In.) | | | | | Bracket Weight (Lbs.) | Use With |
|----------------------|--------------------|----------|-------|-------|----------|-----------------------|--------------------|
| | P | Q | R | S | T | | |
| WUH-01A | 1-3/4 | 21-1/2 | 6-3/4 | 5-1/2 | 14-15/16 | 4-1/2 | LUH-02, 04, 05 |
| WUH-02 | 2 | 28-7/16 | 9-1/2 | 8-3/8 | 22-1/4 | 12-1/4 | LUH-07, 10, 12, 15 |
| WUH-02 | 2 | 28-7/16 | 9-1/2 | 8-3/8 | 22-1/4 | 12-1/4 | LUH-20, 25 |
| WUH-03 | 5-1/2 | 28-11/16 | 5 | 3-1/2 | 33-1/4 | 24-1/4 | LUH-30, 35, 40, 45 |

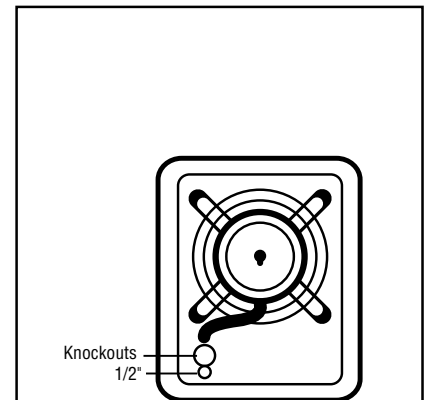

| Knockout Sizes | |
|-----------------|---------------------|
| LUH-02 - LUH-05 | 3/4" (1) |
| LUH-07 - LUH-15 | 1" (1) |
| LUH-20 - LUH-25 | 3/4", 1", 1-1/4"(1) |
| LUH-30 - LUH-45 | 3/4", 1", 1-1/4"(1) |

WIRING

⚠ WARNING

ELECTRIC SHOCK HAZARD. Disconnect all power before installing or servicing heater. Failure to do so could result in personal injury or property damage. Heater must be installed by a qualified person in accordance with the National Electrical Code, NFPA 70.

⚠ WARNING

ELECTRIC SHOCK HAZARD. Any installation involving electric heaters must be performed by a qualified person and must be effectively grounded in accordance with the National Electrical Code to eliminate shock hazard.

1. Use heater only on the voltage and frequency specified on the nameplate.
2. All wiring should be done in accordance with local codes and the National Electrical Code by a qualified person as defined in the NEC.
3. Two knockouts are provided on the back of the heater for wire entry. See Figure 6 for location of knockouts.
4. Branch circuit wire for connection to heater must be at least 60°C wire.
5. The bottom access door is hinged. There is one screw that must be loosened to gain access (Figure 3). This screw is the captive type; do not try to remove it.
6. A ground terminal is provided near the power terminal board. The ground wire should be connected before other connections are made.
7. Stripped wire leads are supplied to be connected to accept the correct size power supply wire. Copper wire rated at 600V and 60°C is satisfactory for the heater branch circuit.
8. Electrical accessories, either kits or factory-installed options, are shown connected by a dash line on the heater wiring diagram.
9. Wiring connections are to be made on designated wire leads as shown in the wiring diagrams located inside the access door.

POWER DISCONNECT SWITCH (Available as a kit or factory installed option.) This switch (Figure 7) disconnects the power to the power leads when the handle is placed in its off position.

1. Use copper conductor supply wire only when connecting to the power line.
2. Connection to the switch pigtails should be made with compression connectors and the joint should be then well insulated.

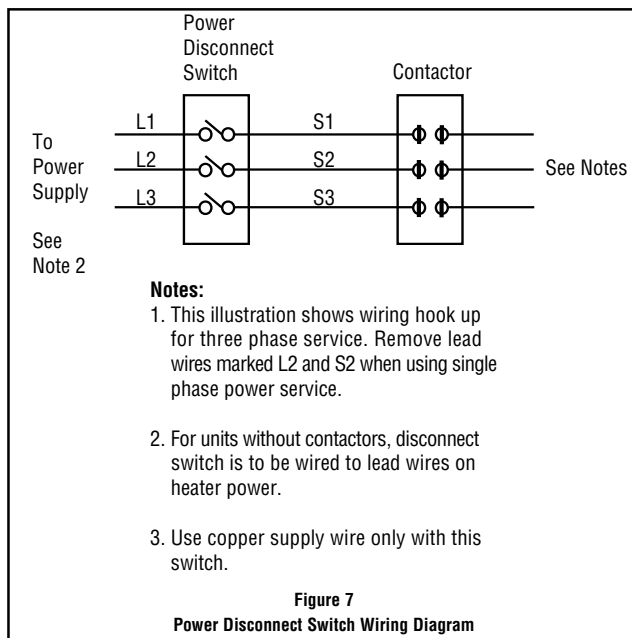

3. Consult the local wiring code in your area.
SUMMER FAN SWITCH (MOUNTED ON FRONT OF HEATER). When the switch handle is pointing toward the “SUMMER” position, the fan will run continuously. When the switch handle is pointing toward the “WINTER” position, the fan will run only when the heating elements are hot.

REMOTE FAN SWITCH (MANUAL SWITCH-LINE VOLT-AGE). 480V requires an additional relay. The wall switch is packed in the wiring compartment.

The remote fan switch is mounted external and remote from the LUH unit heater. The voltage of the remote fan switch is the same as the supply voltage to the LUH heater.

1. Use 14 gauge copper, NEC Class 1, 600V rated insulated wire. Wiring must meet all Local and NEC requirements for 480V service.
2. Install the remote fan switch in standard wall box in any convenient location that is protected from traffic or other accidental damage.
3. Connect the 14 gauge copper field wire to the switch lead wires with suitable connectors.

REMOTE FAN SWITCH (USED WITH 24 or 120-VOLT RELAY) (Available as a kit or factory installed option). The wall switch is packed in the wiring compartment.

1. Use 18 gauge (min.) NEC Class 1, 600V wiring that meets all Local and NEC requirements.
2. Install the wall switch in a standard wall box in any convenient location that is protected from traffic or other accidental damage.
3. Connect the field wire to the switch lead wires with suitable connectors.

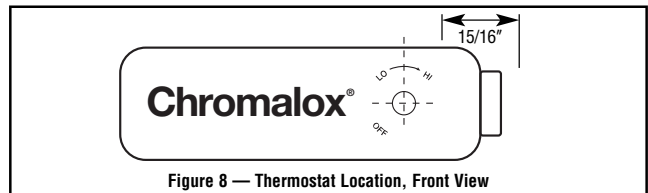

Figure 8 — Thermostat Location, Front View

OPTIONAL THERMOSTAT (LUH-TK)

Heaters can be equipped with an optional thermostat of the Bulb and Capillary type for automatic temperature control (Figure 8). The thermostat controls the heating elements and fan simultaneously to achieve set temperature.

The “Lo” setting of the thermostat is approximately 40°F, and the “Hi” setting is approximately 90°F.

CONTROL VOLTAGE WIRING - EXTERNAL REMOTE THERMOSTATS AND FAN SWITCHES

⚠ WARNING

ELECTRIC SHOCK HAZARD. Line voltage is present on some of the terminals. Always disconnect the power from the heater before making any connections.

1. Use 600V, NEC Class 1 insulated wiring with a minimum gauge of 18 for thermostats and a minimum gauge of 14 for line voltage motor switch (remote fan switch without relay).
2. The thermostat should be located in the area to be heated on an inside wall. The thermostat should not be exposed to drafts, sunlight, radiation from hot objects, or in a direct line with the discharge from the unit heater.
3. Install the thermostat approximately 5 feet above the floor line.
4. Install the remote fan switch in any convenient location that is protected from traffic or likely accidental damage.
5. Internal optional controls are shown on the unit heater wiring diagrams by a dash line.

Use wiring diagrams as listed for model number on (A through X), pages 5, 6 and 9.

For installation and optional control kits, refer to instruction sheets listed on page 8.

WIRING DIAGRAMS

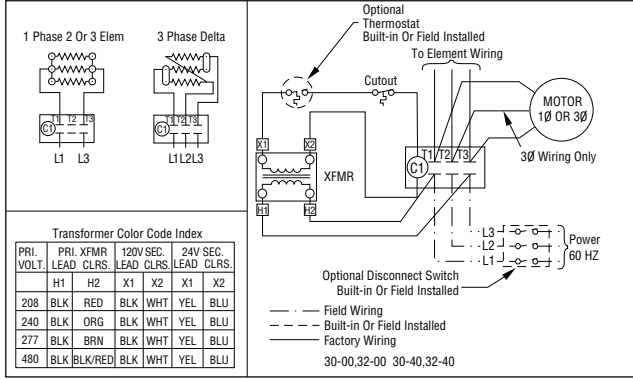

Figure A

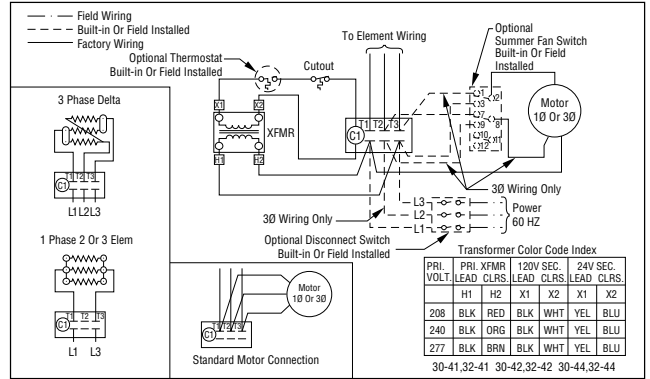

Figure B

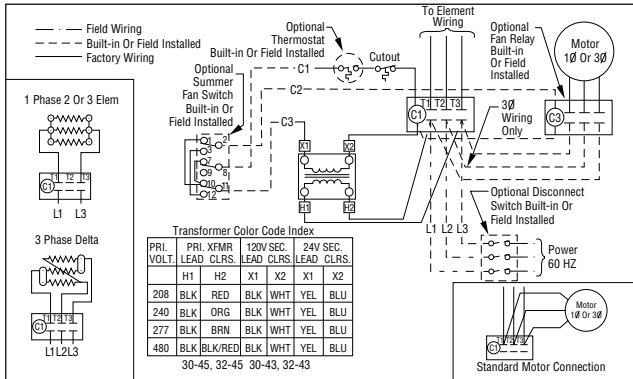

Figure C

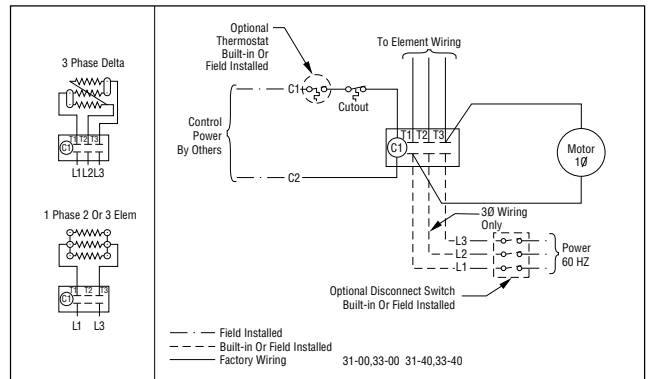

Figure D

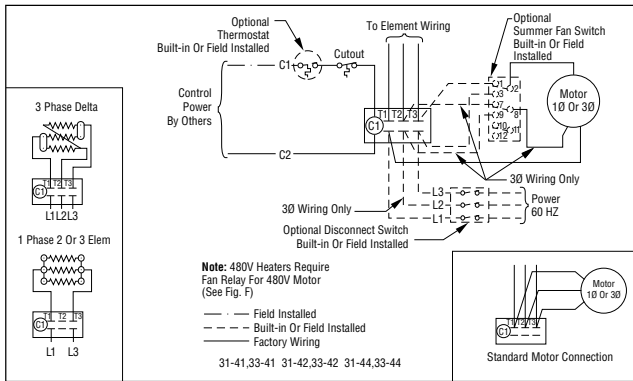

Figure E

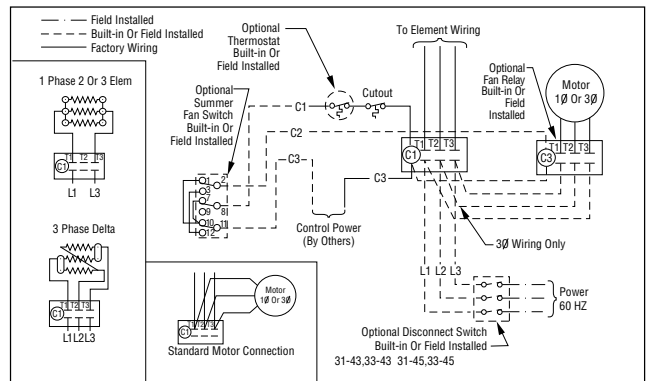

Figure F

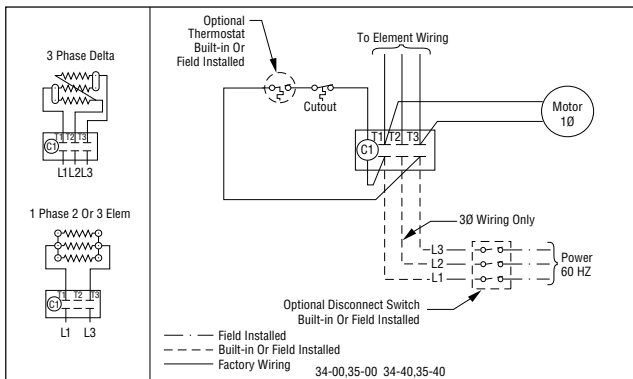

Figure G

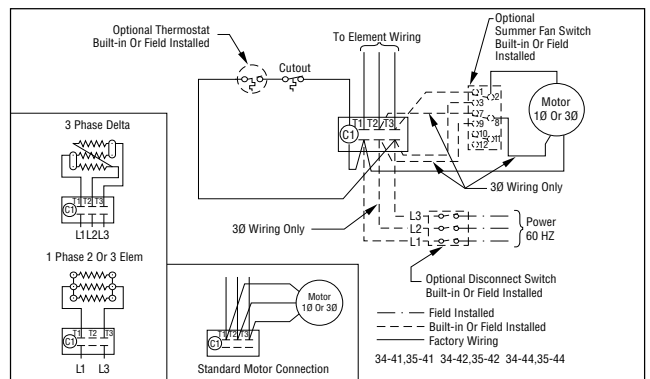

Figure H

WIRING DIAGRAMS

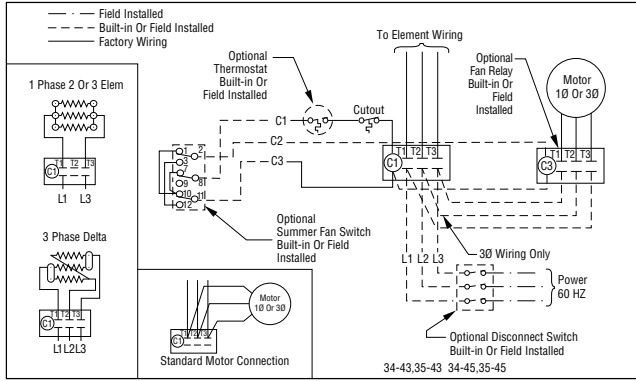

Figure 1

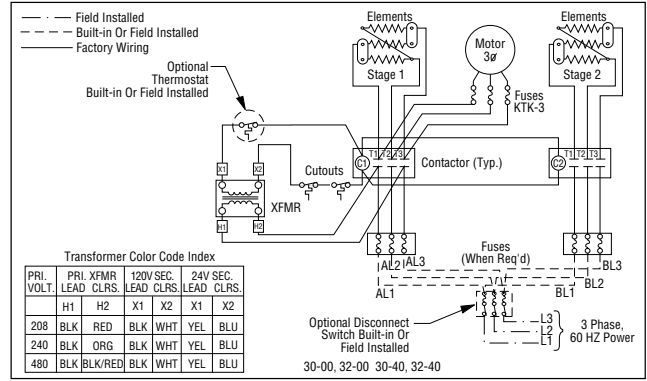

Figure J

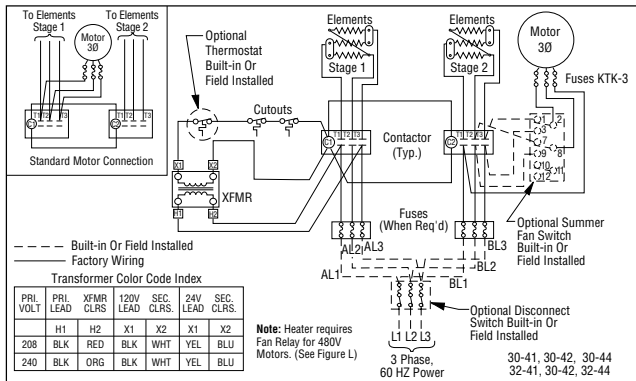

Figure K

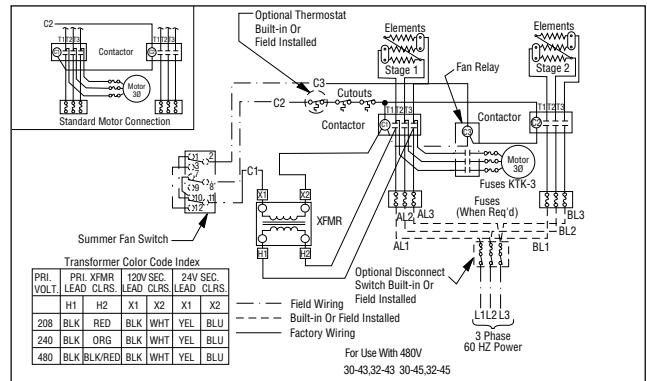

Figure L

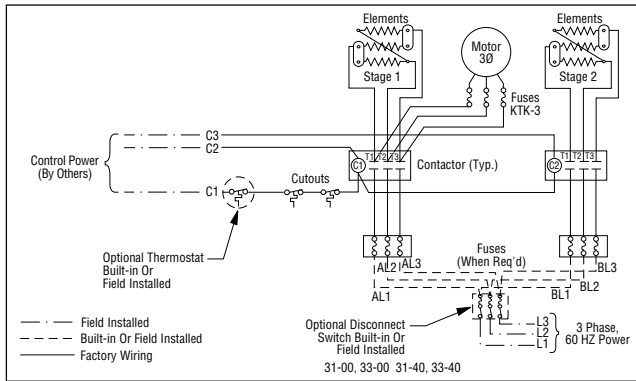

Figure M

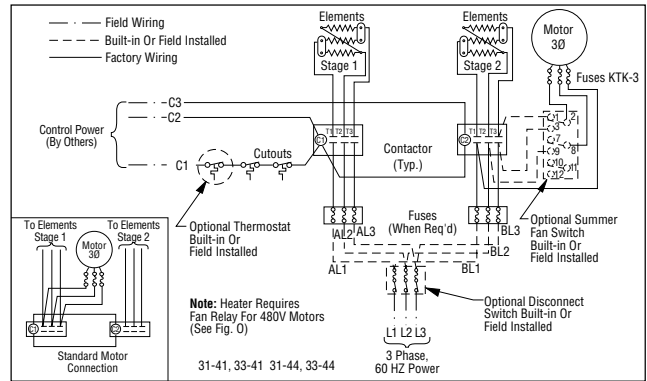

Figure N

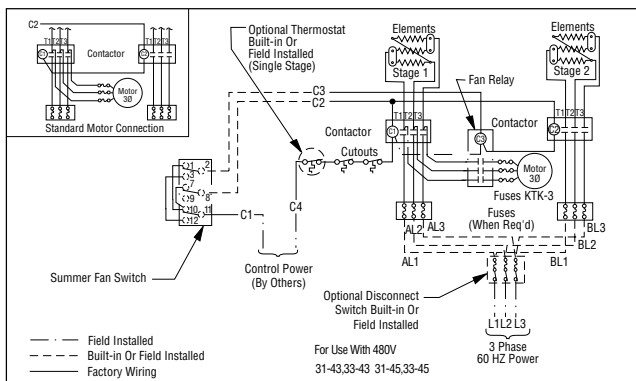

Figure O

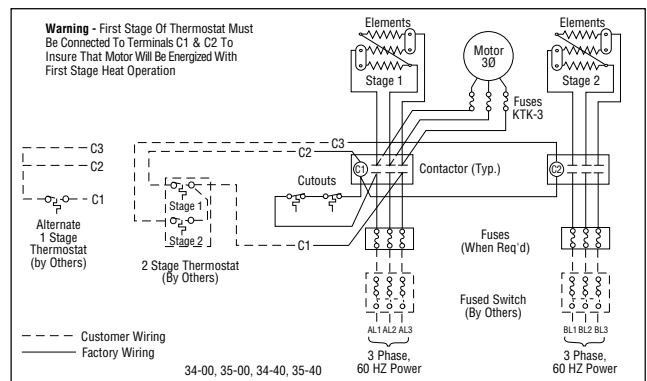
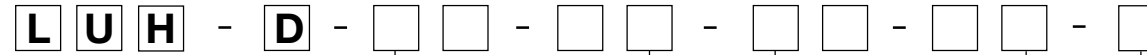

Figure P

RENEWAL PARTS IDENTIFICATION

MANUFACTURER PART NUMBER BREAKDOWN

FOR MADE TO ORDER UNITS
(LOCATED ON UNIT NAMEPLATE)



| Code | kW | Volts | Phase | Element Part No. | Motor Part No. | Fan Part No. |
|-------|----------|---------|-------|--------------------|----------------|----------------|
| 02-81 | 2.67 | 208 | 1 | 118-303160-001 (2) | 193-302912-001 | 112-302997-001 |
| 02-21 | 2.67 | 208/240 | 1 | 118-303160-002 (2) | 193-302912-001 | 112-302997-001 |
| 02-71 | 2.67 | 277 | 1 | 118-303160-003 (2) | 193-302120-001 | 112-130367-001 |
| 04-81 | 4 | 208 | 1 | 118-303160-001 (3) | 193-302912-001 | 112-302997-001 |
| 04-83 | 4 | 208 | 3 | 118-303160-001 (3) | 193-302912-001 | 112-302997-001 |
| 04-21 | 3/4 | 208/240 | 1 | 118-303160-002 (3) | 193-302912-001 | 112-302997-001 |
| 04-23 | 3/4 | 208/240 | 3 | 118-303160-002 (3) | 193-302912-001 | 112-302997-001 |
| 04-71 | 4 | 277 | 1 | 118-303160-003 (3) | 193-302120-001 | 112-130367-001 |
| 04-43 | 4 | 480 | 3 | 118-303160-004 (3) | 193-302912-003 | 112-302997-001 |
| 05-81 | 5 | 208 | 1 | 118-303160-005 (3) | 193-302912-001 | 112-302997-001 |
| 05-83 | 5 | 208 | 3 | 118-303160-005 (3) | 193-302912-001 | 112-302997-001 |
| 05-21 | 3.75/5 | 208/240 | 1 | 118-303160-006 (3) | 193-302912-001 | 112-302997-001 |
| 05-23 | 3.75/5 | 208/240 | 3 | 118-303160-006 (3) | 193-302912-001 | 112-302997-001 |
| 05-71 | 5 | 277 | 1 | 118-303160-007 (3) | 193-302120-001 | 112-130367-001 |
| 05-43 | 5 | 480 | 3 | 118-303160-008 (3) | 193-302912-003 | 112-302997-001 |
| 07-81 | 7.5 | 208 | 1 | 118-303170-005 (3) | 193-302912-004 | 112-130367-007 |
| 07-83 | 7.5 | 208 | 3 | 118-303170-005 (3) | 193-302912-004 | 112-130367-007 |
| 07-21 | 5.6/7.5 | 208/240 | 1 | 118-303170-001 (3) | 193-302912-004 | 112-130367-007 |
| 07-23 | 5.6/7.5 | 208/240 | 3 | 118-303170-001 (3) | 193-302912-004 | 112-130367-007 |
| 07-71 | 7.5 | 277 | 1 | 118-303170-006 (3) | 193-302120-004 | 112-130367-007 |
| 07-43 | 7.5 | 480 | 3 | 118-303170-004 (3) | 193-302912-005 | 112-130367-007 |
| 10-81 | 10 | 208 | 1 | 118-303169-001 (3) | 193-302912-004 | 112-130367-002 |
| 10-83 | 10 | 208 | 3 | 118-303169-001 (3) | 193-302912-004 | 112-130367-002 |
| 10-21 | 7.5/10 | 208/240 | 1 | 118-303169-002 (3) | 193-302912-004 | 112-130367-002 |
| 10-23 | 7.5/10 | 208/240 | 3 | 118-303169-002 (3) | 193-302912-004 | 112-130367-002 |
| 10-43 | 10 | 480 | 3 | 118-303169-003 (3) | 193-302912-005 | 112-130367-002 |
| 12-83 | 12.5 | 208 | 3 | 118-303169-004 (3) | 193-302912-004 | 112-130367-002 |
| 12-23 | 9.4/12.5 | 208/240 | 3 | 118-303169-005 (3) | 193-302912-004 | 112-130367-002 |
| 12-43 | 12.5 | 480 | 3 | 118-303169-006 (3) | 193-302912-005 | 112-130367-002 |
| 15-83 | 15 | 208 | 3 | 118-303169-007 (3) | 193-302912-004 | 112-130367-002 |
| 15-23 | 11.2/15 | 208/240 | 3 | 118-303169-008 (3) | 193-302912-004 | 112-130367-002 |
| 15-43 | 15 | 480 | 3 | 118-303169-009 (3) | 193-302912-005 | 112-130367-002 |
| 20-23 | 15/20 | 208/240 | 3 | 118-130419-010 (3) | 193-302120-005 | 112-130367-003 |
| 20-43 | 20 | 480 | 3 | 118-130419-011 (3) | 193-302120-005 | 112-130367-003 |
| 25-43 | 25 | 480 | 3 | 118-130419-012 (3) | 193-302120-005 | 112-130367-003 |
| 30-83 | 30 | 208 | 3 | 118-130384-013 (6) | 193-302120-005 | 112-130367-004 |
| 30-23 | 22.5/30 | 208/240 | 3 | 118-130384-014 (6) | 193-302120-005 | 112-130367-004 |
| 30-43 | 30 | 480 | 3 | 118-130384-015 (6) | 193-302120-005 | 112-130367-004 |
| 35-23 | 26.2/35 | 208/240 | 3 | 118-130384-021 (6) | 193-302120-005 | 112-130367-004 |
| 35-43 | 35 | 480 | 3 | 118-130384-016 (6) | 193-302120-005 | 112-130367-004 |
| 40-23 | 30/40 | 208/240 | 3 | 118-130384-022 (6) | 193-302120-005 | 112-130367-004 |
| 40-43 | 40 | 480 | 3 | 118-130384-017 (6) | 193-302120-005 | 112-130367-004 |
| 45-43 | 45 | 480 | 3 | 118-130384-018 (6) | 193-302120-005 | 112-130367-004 |

| Description | Part Number | | | |
|-----------------------------|--------------------|--------------------|--------------------|--------------------|
| | 2-5kW | 7.5-15kW | 20-25kW | 30-45kW |
| Louver | 182-130329-001 (4) | 182-130329-002 (5) | 182-130329-003 (6) | 182-130329-003 (6) |
| Louver spring | 276-130368-001 (4) | 276-130368-001 (5) | 276-130368-001 (6) | 276-130368-001 (6) |
| Cut-Out | 300-049200-001 | 300-049200-001 | 300-049200-001 | 300-049200-001 |
| Case Front | 043-130336-014 | 043-130335-011 | 043-130334-008 | 043-130334-008 |
| Case Back | 043-130379-028 | 043-130379-031 | 043-130379-033 | 043-130379-033 |
| Case Wrapper W/O Fuse Door | 043-130314-005 | 043-130315-004 | 043-130316-004 | 043-130317-004 |
| Case Wrapper With Fuse Door | | | | 043-130317-005 |

Power Fuses (Used when heater exceeds 48 Amps)

| Code | Description | Part No. |
|------------------------------|-----------------|--------------------|
| 45-53 | Fuse Block 600V | 129-025643-001 (2) |
| "30-83, 30-23, 35-23, 40-23" | Fuse Block 250V | 129-048473-001 |
| "30-83, 35-23, 40-23" | Fuse 60 Amp | 128-026510-007 (6) |
| 30-23 | Fuse 50 Amp | 128-026510-006 (6) |
| 45-43 | Fuse 35 Amp | 128-026510-001 (6) |

For Contactor Rating, refer to Specification Table shown on Page 1.

| Code | Description | Heater Line Volts | Part No. | Wiring Figure |
|-------|------------------------|-------------------|----------------|---------------|
| 00-40 | Thermostat DP | All | 300-049197-004 | |
| 30-00 | Contactor (24 V) 30A | All | 072-303180-001 | A, J, S |
| | Contactor (24 V) 50A | All | 072-303180-002 | |
| | Transformer | All | 315-304252-002 | |
| 30-40 | Contactor (24 V) 30A | All | 072-303180-001 | A, J |
| | Contactor (24 V) 50A | All | 072-303180-002 | |
| | Transformer | All | 315-304252-002 | |
| | Thermostat SP | All | 300-049197-003 | |
| 30-41 | Contactor (24V) 30A | All | 072-303180-001 | B, K |
| | Contactor (24V) 50A | All | 072-303180-002 | |
| | Transformer | All | 315-304252-002 | |
| | Thermostat SP | All | 300-049197-003 | |
| | Fan Switch 3PDT | All | 292-057673-001 | |
| 30-42 | Contactor (24V) 30A | All | 072-303180-001 | B, K |
| | Contactor (24V) 50A | All | 072-303180-002 | |
| | Transformer | All | 315-304252-002 | |
| | Remote Fan Switch 3PDT | All | 292-057673-001 | |
| | Thermostat SP | All | 300-049197-003 | |
| 30-43 | Contactor (24V) 30A | All | 072-303180-001 | C, L, T |
| | Contactor (24V) 50A | All | 072-303180-002 | |
| | Transformer | All | 315-304252-002 | |
| | Fan Relay | 2.6-5kW | 072-303180-011 | |
| | Fan Relay | 7.5-45kW | 072-303180-001 | |
| | Remote Fan Switch 3PDT | All | 292-057673-001 | |
| 30-44 | Contactor (24V) 30A | All | 072-303180-001 | B, K |
| | Contactor (24V) 50A | All | 072-303180-002 | |
| | Transformer | All | 315-304252-002 | |
| | Remote Fan Switch 3PDT | All | 292-057673-001 | |
| | Thermostat SP | All | 300-049197-003 | |
| 30-45 | Contactor (24V) 30A | All | 072-303180-001 | C, L |
| | Contactor (24V) 50A | All | 072-303180-002 | |
| | Transformer | All | 315-304252-002 | |
| | Remote Fan Switch 3PDT | All | 292-057673-001 | |
| | Fan Relay | 2.6-5kW | 072-303180-011 | |
| | Fan Relay | 7.5-45kW | 072-303180-001 | |
| | Thermostat SP | All | 300-049197-003 | |
| 31-00 | Contactor (24V) 30A | All | 072-303180-001 | D, M, U |
| | Contactor (24V) 50A | All | 072-303180-002 | |
| 31-40 | Contactor (24V) 30A | All | 072-303180-001 | D, M |
| | Contactor (24V) 50A | All | 072-303180-002 | |
| | Thermostat SP | All | 300-049197-003 | |
| 31-41 | Contactor (24V) 30A | All | 072-303180-001 | E, N |
| | Contactor (24V) 50A | All | 072-303180-002 | |
| | Thermostat SP | All | 300-049197-003 | |
| | Fan Switch 3PDT | All | 292-057673-001 | |
| 31-42 | Contactor (24V) 30A | All | 072-303180-001 | E, N, V |
| | Contactor (24V) 50A | All | 072-303180-002 | |
| | Remote Fan Switch 3PDT | All | 292-057673-001 | |
| 31-43 | Contactor (24V) 30A | All | 072-303180-001 | F, O, R |
| | Contactor (24V) 50A | All | 072-303180-002 | |
| | Fan Relay | 2.6-5kW | 072-303180-011 | |
| | Fan Relay | 7.5-45kW | 072-303180-001 | |
| | Remote Fan Switch 3PDT | All | 292-057673-001 | |
| 31-44 | Contactor (24V) 30A | All | 072-303180-001 | E, N |
| | Contactor (24V) 50A | All | 072-303180-002 | |
| | Remote Fan Switch 3PDT | All | 292-057673-001 | |
| | Thermostat SP | All | 300-049197-003 | |
| 31-45 | Contactor (24V) 30A | All | 072-303180-001 | F, O |
| | Contactor (24V) 50A | All | 072-303180-002 | |
| | Fan Relay | 7.5-45kW | 072-303180-011 | |
| | Remote Fan Switch 3PDT | All | 292-057673-001 | |
| | Thermostat SP | All | 300-049197-003 | |
| 32-00 | Contactor (120) 30A | All | 072-303180-007 | A, J, S |
| | Contactor (120) 50A | All | 072-303180-008 | |
| | Transformer | All | 315-304252-001 | |
| 32-40 | Contactor (120) 30A | All | 072-303180-007 | A, J |
| | Contactor (120) 50A | All | 072-303180-008 | |
| | Transformer | All | 315-304252-001 | |
| | Thermostat SP | All | 300-049197-003 | |
| 32-41 | Contactor (120) 30A | All | 072-303180-007 | B, K |
| | Contactor (120) 50A | All | 072-303180-008 | |
| | Transformer | All | 315-304252-001 | |
| | Thermostat SP | All | 300-049197-003 | |
| | Fan Switch 3PDT | All | 292-057673-001 | |
| 32-42 | Contactor (120) 30A | All | 072-303180-007 | B, K |
| | Contactor (120) 50A | All | 072-303180-008 | |
| | Transformer | All | 315-304252-001 | |
| | Remote Fan Switch 3PDT | All | 292-057673-001 | |
| 32-43 | Contactor (120) 30A | All | 072-303180-007 | C, L, T |
| | Contactor (120) 50A | All | 072-303180-008 | |
| | Transformer | All | 315-304252-001 | |
| | Fan Relay | 2.6-5kW | 072-303180-011 | |
| | Fan Relay | 7.5-45kW | 072-303180-001 | |
| | Remote Fan Switch 3PDT | All | 292-057673-001 | |
| 32-44 | Contactor (120) 30A | All | 072-303180-007 | B, K |
| | Contactor (120) 50A | All | 072-303180-008 | |
| | Transformer | All | 315-304252-001 | |
| | Remote Fan Switch | All | 292-057673-001 | |
| | Thermostat SP | All | 300-049197-003 | |

| Code | Description | Heater Line Volts | Part No. | Wiring Figure |
|-------|------------------------|-------------------|----------------|---------------|
| 32-45 | Contactor (120) 30A | All | 072-303180-007 | C, L |
| | Contactor (120) 50A | All | 072-303180-008 | |
| | Transformer | All | 315-304252-001 | |
| | Fan Relay | 2.6-5kW | 072-303180-011 | |
| | Fan Relay | 7.5-45kW | 072-303180-001 | |
| | Remote Fan Switch 3PDT | All | 292-057673-001 | |
| | Thermostat SP | All | 300-049197-003 | |
| 33-00 | Contactor (120) 30A | All | 072-303180-007 | D, M, U |
| | Contactor (120) 50A | All | 072-303180-008 | |
| 33-40 | Contactor (120) 30A | All | 072-303180-007 | D, M |
| | Contactor (120) 50A | All | 072-303180-008 | |
| | Thermostat SP | All | 300-049197-003 | |
| 33-41 | Contactor (120) 30A | All | 072-303180-007 | E, N |
| | Contactor (120) 50A | All | 072-303180-008 | |
| | Fan Switch 3PDT | All | 292-057673-001 | |
| | Thermostat SP | All | 300-049197-003 | |
| 33-42 | Contactor (120) 30A | All | 072-303180-007 | E, N, V |
| | Contactor (120) 50A | All | 072-303180-008 | |
| | Remote Fan Switch 3PDT | All | 292-057673-001 | |
| 33-43 | Contactor (120) 30A | All | 072-303180-007 | F, O, R |
| | Contactor (120) 50A | All | 072-303180-008 | |
| | Fan Relay | 2.6-5kW | 072-303180-011 | |
| | Fan Relay | 7.5-45kW | 072-303180-001 | |
| | Remote Fan Switch 3PDT | All | 292-057673-001 | |
| | Thermostat SP | All | 300-049197-003 | |
| 33-44 | Contactor (120) 30A | All | 072-303180-007 | E, N |
| | Contactor (120) 50A | All | 072-303180-008 | |
| | Remote Fan Switch 3PDT | All | 292-057673-001 | |
| | Thermostat SP | All | 300-049197-003 | |
| 33-45 | Contactor (120) 30A | All | 072-303180-007 | F, O |
| | Contactor (120) 50A | All | 072-303180-008 | |
| | Fan Relay | 2.6-5kW | 072-303180-011 | |
| | Fan Relay | 7.5-45kW | 072-303180-001 | |
| | Remote Fan Switch 3PDT | All | 292-057673-001 | |
| | | | | |

WIRING DIAGRAMS

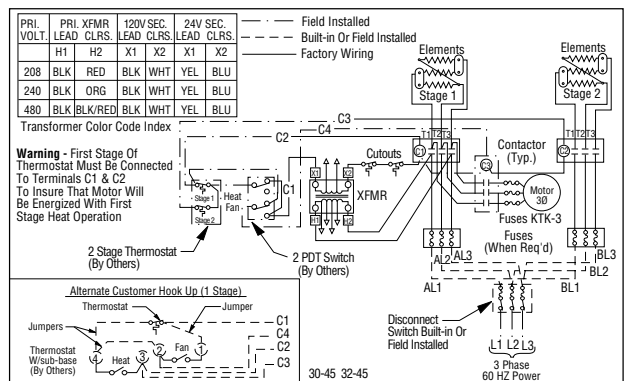
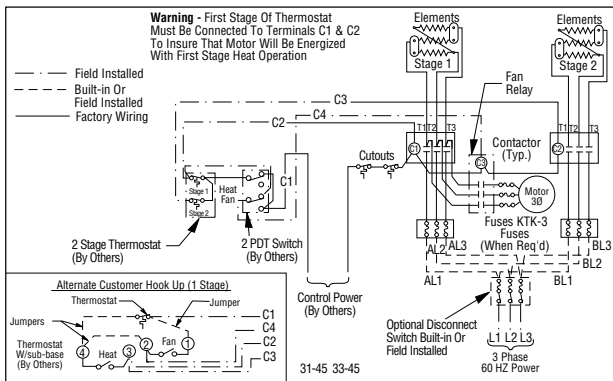
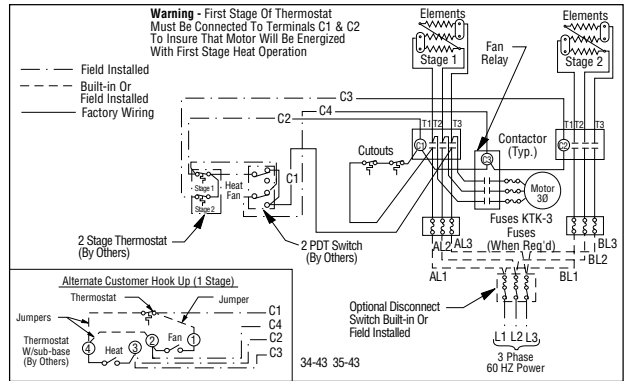
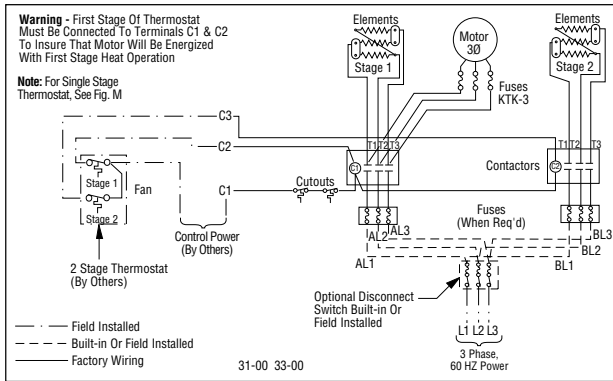
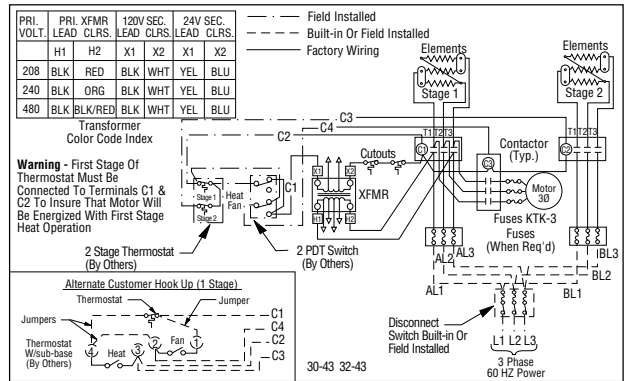
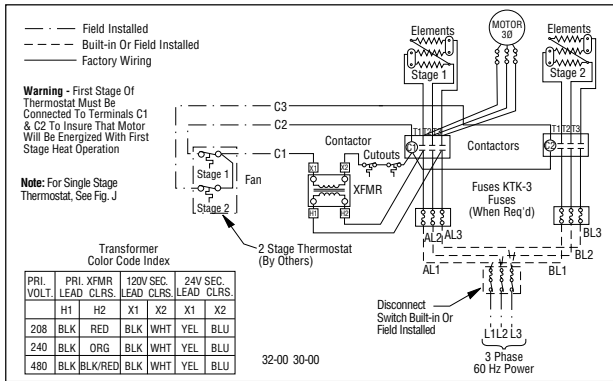
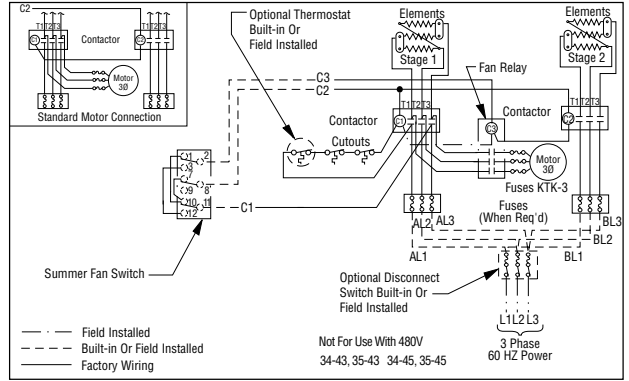
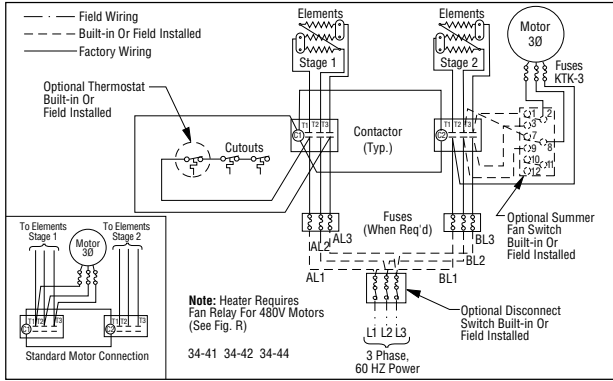

Limited Warranty:

Please refer to the Chromalox limited warranty applicable to this product at <http://www.chromalox.com/customer-service/policies/termsofsale.aspx>.

Chromalox[®]
PRECISION HEAT AND CONTROL

2150 N. RULON WHITE BLVD., OGDEN, UT 84404
Phone: 1-800-368-2493 www.chromalox.com