

Chromalox

Installation, Operation and **RENEWAL PARTS IDENTIFICATION**

SERVICE REFERENCE

DIVISION 4	SECTION RAD
SALES REFERENCE (Supersedes PG404-9)	PG404-10
161-048215-001	
DATE	APRIL, 2005

Type RAD (Style 3B) Electric Radiant Heaters



The Safety Alert Symbol  is used to indicate a risk of personal injury

Familiarize yourself with these instructions before attempting to install or operate this Radiant Heater.

WARNING

The system designer is responsible for the safety of this equipment and should install adequate back-up controls and safety devices with their electric heating equipment. Where the consequences of failure could result in personal injury or property damage, back-up controls are essential.

Before Installing

1. Open carton and remove heater at the place of installation. Mounting clamps are in parts bag in carton.
2. Check nameplate volt and watt rating against your power supply voltage and heating requirements of your installation. This nameplate is located on one end of the heater.

Specifications Table –

Model	Volts	kW	Length (In.)	
			Overall	Heated
RAD-2063BX35	120	0.4	13-5/8	7-3/4
RAD-2063BX29	120	.65	20	14-1/8
RAD-2083B	120 or 240	0.8	24-3/8	16-1/2
RAD-2083BV	208 or 275	0.8		
RAD-3113B	120 or 240	1.1	30-5/8	22-3/4
RAD-3113BV	208 or 275	1.1		
RAD-3133BV	208 or 275	1.3	35-7/8	28-5/16
RAD-3133B	240 or 480	1.3		
RAD-4183BV	208 or 275	1.8	46-5/8	38-1/2
RAD-4183B	240 or 480	1.8		
RAD-5213BV	208 or 275	2.15	53-7/8	45-7/16
RAD-5213B	240 or 480	2.15		
RAD-5253BV	208 or 275	2.5	61-3/8	53-3/8
RAD-5253B	240 or 480	2.5		
RAD-6273BV	208 or 275	2.7	65-7/8	58-1/4
RAD-6273B	240 or 480	2.7		
RAD-6303BV	208 or 275	3.0	73-3/4	65-3/4
RAD-6303B	240 or 480	3.0		
RAD-7333BV	208 or 275	3.35	79-7/8	72-1/4
RAD-7333B	240 or 480	3.35		
RAD-7363BV	208 or 275	3.6	85-3/4	78
RAD-7363B	240 or 480	3.6		
RAD-8453BV	208 or 275	4.5	106	97-1/2
RAD-8453B	240 or 480	4.5		

INSTALLATION

⚠ WARNING

ELECTRIC SHOCK HAZARD. Disconnect all power before installing or servicing heater. Failure to do so could result in personal injury or property damage. Heater must be installed or serviced by a qualified person in accordance with the National Electrical Code, NFPA 70.

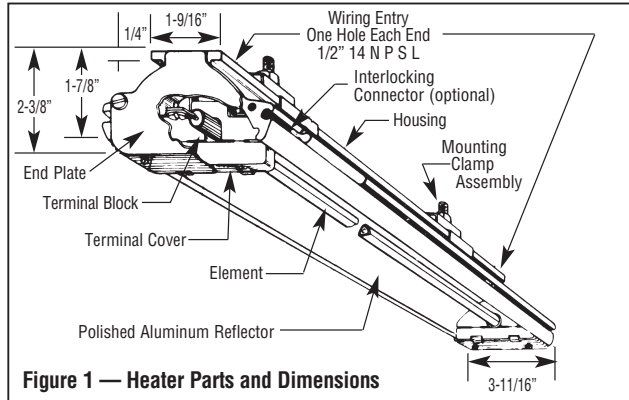
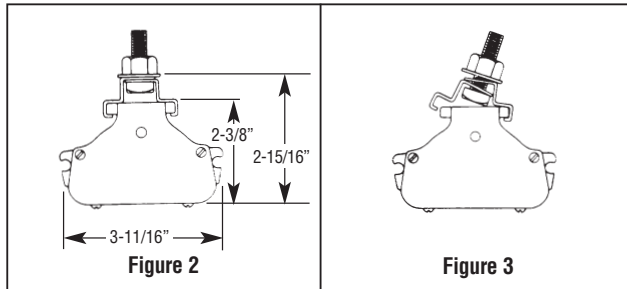

Figure 1 — Heater Parts and Dimensions

1. These radiant heaters are designed for indoor installation only.
2. **Clamps** — Heaters are mounted by means of the mounting clamp and 3/8" bolt assembly which is used as shown in Figure 2. Clamp assembly may be attached to heater by sliding over end or by snapping over top of extruded aluminum frame section at any point along its length. (See Figure 3.) For proper heater support, the maximum distance between clamps must not exceed 48". On extra-long heaters, more than two clamps are furnished.



3. **Mounting Holes** — When heaters are mounted adjacent to each other in the same plane, note that distance between mounting holes on framing to support heaters will be 3-11/16" minimum. When heaters are not in the same plane, i.e. set at an angle to one another, distance between mounting holes in framing will be either greater or less than 3-11/16".
4. **Framing** — Where an extensive installation is being made, the use of continuous slot metal framing manufactured by others will be of assistance in saving time and money. The framing is reusable.

5. **Reflector Spacer Sheets** — Where heaters are not mounted side by side (see Figure 4), reflector spacer sheets can be used between heaters. These reflector spacer sheets and companion reflectors consisting of an extruded aluminum housing with reflector sheets and mounting clamps are available. Check factory.

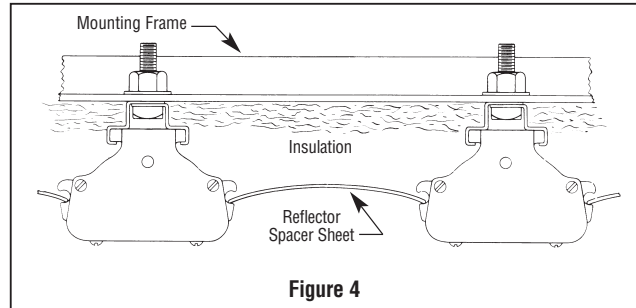

Figure 4

6. **Insulation** — Where unusually high work temperatures are encountered, it may be desirable to insulate backs of heaters with high-temperature fibrous insulation. A suggested method of accomplishing this is indicated in Figure 4.
7. **Ventilation** — Where solvents, water, etc. are being evaporated from work in process, it is necessary to provide substantial quantities of ventilation air to carry away the resulting vapors.

⚠ WARNING

FIRE HAZARD. Since Radiant heaters are capable of developing high temperatures, extreme care should be taken to:

A. Keep combustible materials at least 6" away from sides and back of heater housing and its supporting brackets and spaced far enough in front of heater (heating element side) so thermal radiation from the elements will not ignite combustible materials.

B. If combustible materials are being processed, stoppage of process should initiate immediate heater shutdown and interception of residual heat from radiant heaters (use radiation baffles or move heaters away from work).

C. In the case of solvents of an explosive nature, ventilation air must be in sufficient volume to dilute the solvent vapor so that explosive mixtures cannot occur, refer to NFPA 86, Standard for Ovens and Furnaces.

WIRING

⚠ WARNING

ELECTRIC SHOCK HAZARD. Disconnect all power before installing or servicing heater. Failure to do so could result in personal injury or property damage. Heater must be installed by a qualified person in accordance with the National Electrical Code, NFPA 70.

⚠ WARNING

ELECTRIC SHOCK HAZARD. Any installation involving electric heaters must be performed by a qualified person and must be effectively grounded in accordance with the National Electrical Code to eliminate shock hazard.

1. Electric connection to the Radiant Heater is made through two openings tapped for 1/2" connector. Openings are in the top of the extruded heater housing, one near each end.
2. Access to Radiant Heater terminals is obtained by removing the two screws in each of the terminal box covers.
3. Wiring should run in flexible or rigid metal conduit and must be installed in accordance with the requirements of the National Electrical Code and such other local requirements by a qualified person.
4. Wires supplying power to heating element terminals shall have insulation rated for 150°C Minimum.

CAUTION

High temperatures will oxidize copper. Use only nickel-plated copper wire for supplying power to heater. Do not use aluminum conductors.

5. A sufficient length of this wire (not less than 12") should be used to extend from each heater terminal into a connection box location where the temperature does not exceed 300°F.
6. Leave generous loop in wire when connecting to allow for expansion of heating element.

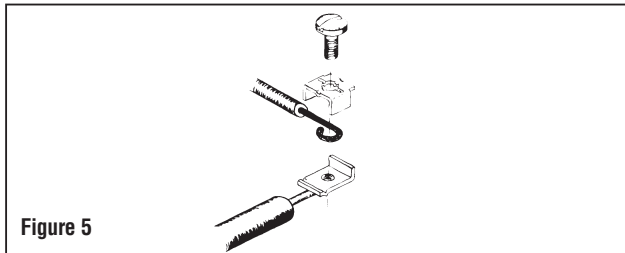

Figure 5

7. Assemble terminal, screw and wire as shown in Figure 5.
8. Hold terminal with pliers and tighten the terminal screw securely with a screwdriver.

Note: Where circuit wiring is installed in locations of high ambient temperature, conductors should be insulated in accordance with requirements for temperature and voltage.

9. **SINGLE END WIRING** may be made through one of the wiring entries by bringing a lead through it from the opposite end of the heating element using the wire-way provided behind integral reflector in the housing extrusion. Wire used in making such connections must be able to operate in high ambient and have a sufficiently high voltage rating for the specific application. The maximum wire diameter is limited by the wire-way and must not exceed .224" over the insulation.

10. **SERIES CONNECTION** of Radiant Heaters of equal volt and watt rating is permitted in all line voltages up to 600 volts. In making such series connections it is necessary to observe the "right" (series-parallel) connection rather than the "wrong" (parallel-series) connection both shown in Figure 6. If heaters are connected according to the "wrong" illustration, failure of any one heater will cause progressive failure of other heaters still operating.

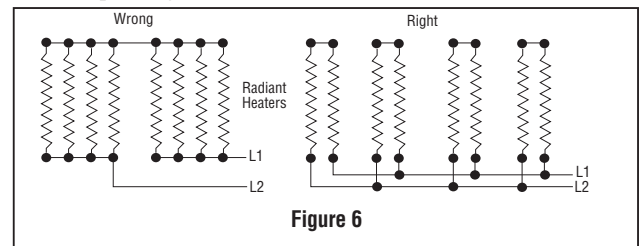

Figure 6

11. **DELTA CONNECTIONS** – When heaters occur in multiples of three, they may be connected to, and balanced across, three-phase lines. The most commonly used connection is the delta connection illustrated in Figure 7.

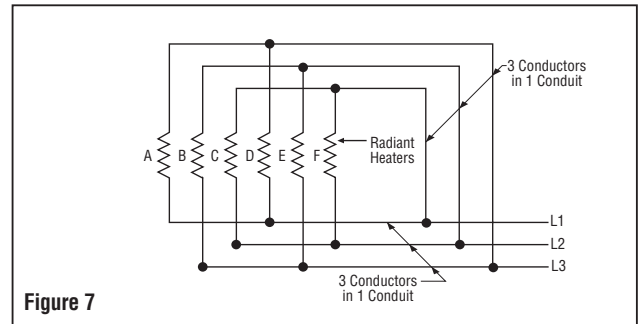

Figure 7

Three phase Delta connections to minimize inductive effect in conduits are made per this diagram. The rule: run all 3 three-phase conductors in the same conduit as far as possible. For single-phase, run only two conductors and follow the same rule.

OPERATION

⚠ WARNING

FIRE/EXPLOSION HAZARD. This heater is not intended for use in hazardous atmospheres where flammable vapors, gases, liquids or other combustible atmospheres are present as defined in the National Electrical Code. Failure to comply can result in personal injury or property damage.

Before energizing this heater:

1. **Be sure** all electrical connections are tightly made. Hold terminal with pliers when tightening screw.
 2. **Be sure** that all conductors are properly insulated, and that they will not chafe at the heater wire entrance due to expansion and contraction of the heating element.
 3. **Be sure** that all terminal covers have been properly replaced, and that secondary insulation bushings have not been omitted.
- A. Controlling Radiant Intensity** — Standard Radiant Heaters are built to operate at approximately 40 watts per sq. inch on the element sheath. When it is desired to reduce radiant intensity, one or more of the following methods may be used.
- i. **INPUT CONTROLLERS.** These motor-driven cycling devices can be used to vary heater output capacity from 4 to 100%. They are usually connected in holding coil circuit of magnetic contactors. See Chromalox Radiant Heater Manual for further information regarding Input Controllers and Contactors.
 - ii. **SOLID STATE POWER CONTROLLERS.** For best non-contact control of radiant heat, a Chromalox SCR Power Controller with manual potentiometer setting is recommended. Truly proportional output of from 0-100% can be easily dialed-in to suit the particular product or process requirements. The panels are pre-engineered, prepackaged assemblies in an enclosure with circuit disconnect provided and ready for installation.

B. Maximum Ambient Temperatures —

Chromalox Radiant Heaters are not recommended for applications in ambient temperature exceeding 450°F. Higher ambient temperatures mean shorter heater life.

Maximum work temperature in a given time depends on several factors: Reflectivity of work, specific heat of work, mass of work, kW input and losses from oven, and time of exposure. As work temperature increases, the work loses heat by radiation and by convection to the surrounding ambient. Although it is a general principle of Radiant Heater application that work temperature conventionally exceeds ambient temperature, in cases where extremely high work temperatures are desired, it is necessary to enclose the heaters in order to increase the ambient. If evaporation of a liquid is desired as a result of increasing work temperature, it is necessary to provide ventilation air in order to carry away the evaporated liquid. Under carefully engineered circumstances, a maximum work temperature of 600°F may be attained.

MAINTENANCE

⚠ WARNING

ELECTRIC SHOCK HAZARD. Disconnect all power before installing or servicing heater. Failure to do so could result in personal injury or property damage. Heater must be installed by a qualified person in accordance with the National Electrical Code, NFPA 70.

A. To remove Heating Element —

1. Remove terminal cover screws and terminal cover.
2. Disconnect heating element from electrical leads at both ends.
3. Remove screws from porcelain terminal blocks.
4. Remove element support clips and secondary insulating bushings.
5. Lift element out of heater.

B. To Install Element —

Observe instructions for removing element and proceed in reverse fashion. Be sure to replace secondary insulating bushings.

C. Care of Reflectors —

Reflectors should be cleaned periodically. A mild soap and water solution or fine cleaning powder is best, although more drastic means may be required if reflectors are badly soiled by chemical or other deposits. The reflector is aluminum. DO NOT use alkali cleaners since alkalies will dull reflector. Mild non-alkaline cleaners, such as used for scouring kitchen sinks, may be used. Reflectors are replaceable and may be purchased from Chromalox.

RENEWAL PARTS IDENTIFICATION

Model	Volts	kW	① Element Model	② Reflector Sheet	⑥ Insulation Bushing	⑦ Element Support Clip
RAD-2063BX35	120	400	RTU-2063AX35	234-013411-031	_____	_____
RAD-2063B	120	600	RTU-2063A-120V	234-013411-011	_____	_____
RAD-2063B	240	600	RTU-2063A-240V	234-013411-011	_____	_____
RAD-2063BX29	120	650	RTU-2063AX29	234-013411-023	_____	_____
RAD-2073B	120 240	700	RTU-2073A-120V RTU-2073A-240V	234-013411-011	_____	_____
RAD-2083B	120 208 240 275	800	RTU-2083A-120V RTU-2083AV-208V RTU-2083A-240V RTU-2083AV-275V	234-013411-011	_____	_____
RAD-3083B	120 240	800	RTU-3083A-120V RTU-3083A-240V	234-013411-012	_____	_____
RAD-3093B	240	900	RTU-3093A-240V	234-013411-012	_____	_____
RAD-3103B	240	1000	RTU-3103A-240V	234-013411-012	_____	_____
RAD-3113B	120 208 240 275	1100	RTU-3113A-120V RTU-3113AV-208V RTU-3113A-240V RTU-3113AV-275V	234-013411-012	_____	_____
RAD-3133B	208 240 275 480	1300	RTU-3133AV-208V RTU-3133A-240V RTU-3133AV-275V RTU-3133A-480V	234-013411-013	_____	_____
RAD-4153B	240	1500	RTU-4153A-240V	234-013411-014	032-013454-001 (2)	059-013424-001
RAD-4163B	240	1600	RTU-4163A-240V	234-013411-014	032-013454-001 (2)	059-013424-001
RAD-4173B	240	1700	RTU-4173A-240V	234-013411-014	032-013454-001 (2)	059-013424-001
RAD-4183B	208 240 275 480	1800	RTU-4183AV-208V RTU-4183A-240V RTU-4183AV-275V RTU-4183A-480V	234-013411-014	032-013454-001 (2)	059-013424-001
RAD-5213B	208 240 275 480	2150	RTU-5213AV-208V RTU-5213A-240V RTU-5213AV-275V RTU-5213A-480V	234-013411-015	032-013454-001 (4)	059-013424-001 (2)
RAD-5253B	208 240 275 480	2500	RTU-5253AV-208V RTU-5253A-240V RTU-5253AV-275V RTU-5253A-480V	234-013411-016	032-013454-001 (6)	059-013424-001 (3)
RAD-6273B	208 240 275 480	2700	RTU-6273AV-208V RTU-6273A-240V RTU-6273AV-275V RTU-6273A-480V	234-013411-017	032-013454-001 (6)	059-013424-001 (3)
RAD-6303B	208 240 275 480	3000	RTU-6303AV-208V RTU-6303A-240V RTU-6303AV-275V RTU-6303A-480V	234-013411-018	032-013454-001 (8)	059-013424-001 (4)
RAD-7333B	208 240 275 480	3350	RTU-7333AV-208V RTU-7333A-240V RTU-7333AV-275V RTU-7333A-480V	234-013411-006* and 234-013411-015*	032-013454-001 (8)	059-013424-001 (4)
RAD-7363B	208 240 275 480	3600	RTU-7363AV-208V RTU-7363A-240V RTU-7363AV-275V RTU-7363A-480V	234-013411-004* and 234-013411-012*	032-013454-001 (10)	059-013424-001 (5)
RAD-8453B	208 240 275 480	4500	RTU-8453AV-208V RTU-8453A-240V RTU-8453AV-275V RTU-8453A-480V	234-013411-049 (2)	032-013454-001 (10)	059-013424-001 (5)

* For ease of installation, these reflectors shipped in two pieces (one each of part numbers listed).

PARTS COMMON TO ALL HEATERS

③ Terminal Cover	306-014405-001 (2)	⑮ Saddle Clamp	238-026539-001 (2)
④ Terminal Cover Clip	056-014401-002 (4)		
⑤ End Plates	220-014462-001 †		
	220-014462-002		
⑧ Terminal Screw	248-046044-002		

† indicates stamped end plate with voltage, wattage, etc.

NOTE: Part numbers suffixed by a number in () indicates the quantity of the same part number used.

RENEWAL PARTS IDENTIFICATION

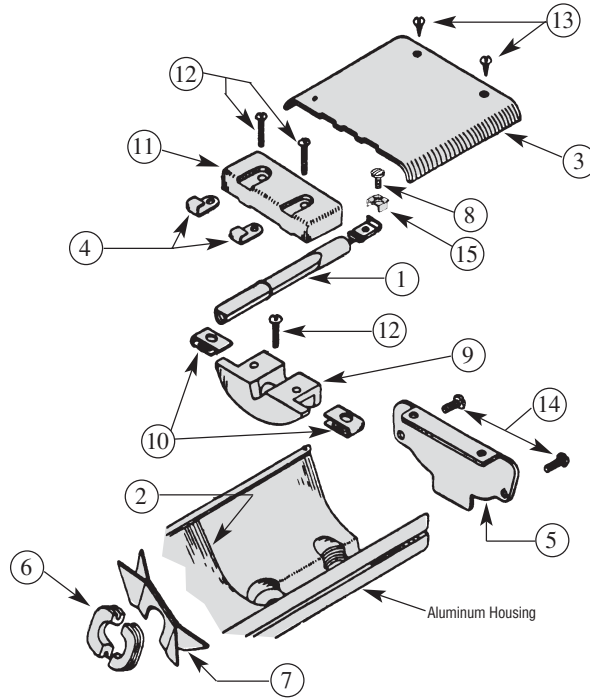

MISCELLANEOUS HARDWARE

Screws —

- (12) #8 x 1" Lg. 248-075519-095 (6)
- (13) #8 x 3/8" Lg. 248-075519-080 (4)
- (14) #8-32 x 3/8" Lg. 248-075512-053 (4)

MISCELLANEOUS PARTS

- (9) Terminal Blocks 303-016367-001 (2)
- (10) Speed Nuts — 272-048153-005 (4)
- (11) Terminal Block — 303-014326-001 (2)

TERMINAL BLOCK SET

168-016585-001 consists of the following:

- (9) Terminal Block 303-016367-001 (2)
- (10) Speed Nuts 272-048153-005 (4)
- (11) Terminal Block 303-014326-001 (2)
- (12) Screws — #8 x 1" Lg. 248-075519-095 (6)

HEATER MOUNTING CLAMP ASSEMBLY

See Figures 1, 2, 3 and 4, page 1.

For mounting heater with catalog numbers up to Cat. No. RAD 7000 use mounting clamp assembly Part No. 168-013071-001. For mounting heaters above Cat. No. RAD 7000 use mounting clamp assembly Part No. 168-013071-002.

NOTE: Part numbers suffixed by a number in () indicates the quantity of the same part number used.

Limited Warranty:

Please refer to the Chromalox limited warranty applicable to this product at <http://www.chromalox.com/customer-service/policies/termsforsale.aspx>.

Chromalox®
PRECISION HEAT AND CONTROL

2150 N. RULON WHITE BLVD., OGDEN, UT 84404
 Phone: 1-800-368-2493 www.chromalox.com