

RAD-H

Hermetically Sealed Single Element Radiant Heater



- 1.83 kW/Ft²
- 0.7 - 3.6 kW
- 120 and 240 Volt
- 3/8" Dia. INCOLOY® Sheath Elements (type RTUH)
- 1000°F Max. Sheath Temp.

Dimensions (Inches)

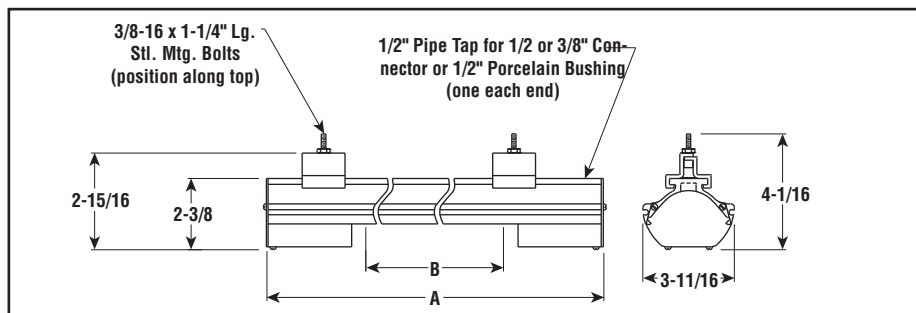

Applications

- Humid Area Environments
- Rubber and Synthetic Fabric Processing
- Meat and Food Processing

Features

Complete, Ready-to-Connect Assembly available in various lengths to accommodate work of varying dimensions.

Movable Mounting Clamps and Bolts are supplied to accommodate many mounting configurations such as banks, tunnels and oven sections.

Process Temperature Control — Radiant heater output may be controlled with Chromalox SCR Power Controllers, Percentage Timing Input Controls and Non-Contact Temperature Sensors. See the Controls section of this catalog.

Additional Sizes and Ratings — Contact your Local Chromalox Sales office for price and availability.

Construction

Hermetically Sealed, Enclosed Chromalox Alloy-Sheath Tubular Heating Element is completely isolated and supported on secondary insulation for improved electrical safety. Designed for long life, the element is more resistant to hard blows than quartz lamp or tube and open coil types.

Rigid Extruded Aluminum Housing protects heating element from harsh industrial environments.

Highly Polished Aluminum Reflectors give good reflectivity and heat transfer, and are easily cleaned to maintain energy efficiency.

Accessories

Protective Grille — Optional snap-in sections help protect personnel and work from contact with hot elements.

Companion Reflector — Optional radiant companion reflectors improve oven efficiency.

Specifications and Ordering Information

| kW | Volts | Length (In.) | | Model | Stock | PCN | Optional Grille | Replacement Elements | Wt. (Lbs.) |
|-----|-------|--------------|----------|-----------|-------|--------|-----------------|----------------------|------------|
| | | Overall A | Heated B | | | | | | |
| 0.7 | 120 | 24-3/8 | 14-1/2 | RAD-H-207 | NS | 115570 | (1) GR-800 | RTUH-207 | 5 |
| 0.7 | 240 | 24-3/8 | 14-1/2 | RAD-H-207 | NS | 115588 | (1) GR-800 | RTUH-207 | 5 |
| 1 | 120 | 30-5/8 | 20-3/4 | RAD-H-310 | NS | 115596 | (1) GR-2 | RTUH-310 | 6 |
| 1 | 240 | 30-5/8 | 20-3/4 | RAD-H-310 | NS | 115609 | (1) GR-2 | RTUH-310 | 6 |
| 1.8 | 240 | 46-5/8 | 36-1/2 | RAD-H-418 | NS | 115617 | (2) GR-2 | RTUH-418 | 9 |
| 2.5 | 240 | 61-3/8 | 51-3/8 | RAD-H-525 | NS | 115625 | (3) GR-2 | RTUH-525 | 11 |
| 3 | 240 | 73-3/4 | 63-3/4 | RAD-H-630 | NS | 115633 | (2) GR-3 | RTUH-630 | 13 |
| 3.6 | 240 | 85-3/4 | 76 | RAD-H-736 | NS | 115641 | (2) GR-4 | RTUH-736 | 15 |

Stock Status: S = stock NS = non-stock

To Order — Specify model, PCN, kW, volts, quantity, optional grille and replacement elements (if needed).

METAL SHEATH RADIANT