

Chromalox®

Installation, Operation and RENEWAL PARTS IDENTIFICATION

SERVICE REFERENCE	
DIVISION 4	SECTION RADD
SALES REFERENCE (Supersedes PG412-9)	PG412-10
161-026681-001	
DATE	DECEMBER, 2008

The Safety Alert Symbol  is used to indicate a risk of personal injury.

Please familiarize yourself with these instructions before attempting to install or operate this Radiant Heater.

Type RADD Electric Radiant Heaters

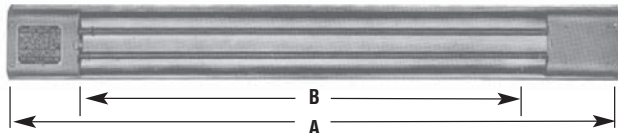

Before Installing:

1. Open carton and remove heater at the place of installation. Mounting clamps are in parts bag in carton.
2. Check nameplate volt and watt rating against your power supply voltage and heating requirements of your installation. This nameplate is located on one end of the heater.

WARNING

The system designer is responsible for the safety of this equipment and should install adequate back-up controls and safety devices with their electric heating equipment. Where the consequences of failure could result in personal injury or property damage, back-up controls are essential.

Specifications

Model No.	Volts	kW	A Overall Length	B Heated Length
RADD-2164 RADD-2164V	120 or 240 208 or 275	1.6	24-3/8	16-1/2
RADD-3224 RADD-3224V	120 or 240 208 or 275	2.2	30-5/8	22-3/4
RADD-3264V RADD-3264	208 or 275 240 or 480	2.6	35-7/8	28-5/16
RADD-4364V RADD-4364	208 or 275 240 or 480	3.6	46-5/8	38-1/2
RADD-5434V RADD-5434	208 or 275 240 or 480	4.3	53-7/8	45-7/16
RADD-5504V RADD-5504	208 or 275 240 or 480	5.0	61-3/8	53-3/8
RADD-6544V RADD-6544	208 or 275 240 or 480	5.4	65-7/8	58-1/4
RADD-6604V RADD-6604	208 or 275 240 or 480	6.0	73-3/4	65-3/4
RADD-7674V RADD-7674	208 or 275 240 or 480	6.7	79-7/8	72-1/4
RADD-7724V RADD-7724	208 or 275 240 or 480	7.2	85-3/4	78
RADD-8904V RADD-8904	208 or 275 240 or 480	9.0	106	97-1/2
RADD-7604X10	240 or 480	8.0	114-1/8	106
RADD-7604X13	240 or 480	10	141	132
RADD-7604X9A	240 or 480	11	160-5/8	150
RADD-7724X38	240 or 480	13	185-5/8	174

INSTALLATION

WARNING

ELECTRIC SHOCK HAZARD. Disconnect all power before installing or servicing heater. Failure to do so could result in personal injury or property damage. Heater must be installed or serviced by a qualified person in accordance with the National Electrical Code, NFPA 70.

1. These radiant heaters are designed for indoor installation only.
2. **Mounting Clamps** — Mount heaters by using the mounting clamp and 3/8" bolt assembly.

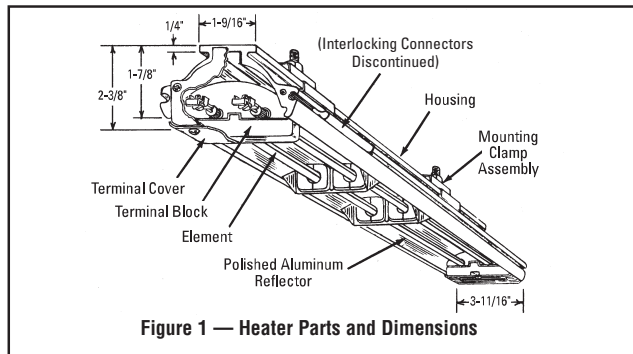

Figure 1 — Heater Parts and Dimensions

Clamp assembly may be attached to heater by sliding over end or by snapping over top of extruded frame section at any point along its length. (see Fig. 2) For proper heater support, the maximum distance between clamps must not exceed 48". On extra-long heaters, more than two clamps are furnished.

3. **Mounting Holes** — When heaters are mounted adjacent to each other in the same plane, note that distance between mounting holes on framing to support heaters will be 3-11/16" minimum. When heaters are not in the same plane, i.e., set at an angle to one another, distance between mounting holes in framing will be either greater or less than 3-11/16".
4. **Framing** — Where an extensive installation is being made, the use of continuous slot metal framing manufactured by several concerns will be of assistance in saving time and money. The framing is reusable.

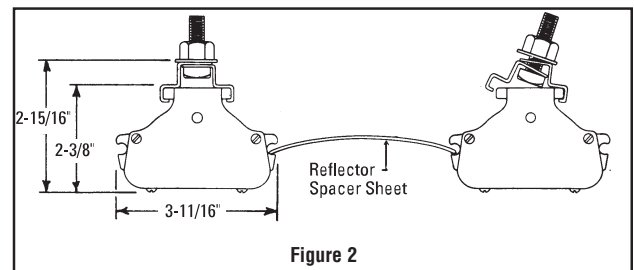

Figure 2

INSTALLATION (cont'd.)

5. **Reflector Spacer Sheets** — Where heaters are not mounted side by side (see Fig. 2), reflector spacer sheets can be used between heaters. These reflector spacer sheets and companion reflectors consisting of an extruded aluminum housing with reflector sheet and mounting clamps are available. Check factory.

⚠ WARNING

FIRE HAZARD: Since Radiant heaters are capable of developing high temperatures, extreme care should be taken to:

- A. Keep combustible materials at least 6" away from sides and back of heater housing and its supporting brackets and spaced far enough in front of heater (heating element side) so thermal radiation from the elements will not ignite combustible materials.**

B. If combustible materials are being processed, stoppage of process should initiate immediate heater shutdown and interception of residual heat from radiant heaters (use radiation baffles or move heaters away from work).

C. In the case of solvents of an explosive nature, ventilation air must be in sufficient volume to dilute the solvent vapor so that explosive mixtures cannot occur, refer to NFPA 86, Standard for Ovens and Furnaces.

WIRING

⚠ WARNING

ELECTRIC SHOCK HAZARD. Disconnect all power before installing or servicing heater. Failure to do so could result in personal injury or property damage. Heater must be installed or serviced by a qualified person in accordance with the National Electrical Code, NFPA 70.

⚠ WARNING

ELECTRIC SHOCK HAZARD. Any installation involving electric heaters must be performed by a qualified person and must be effectively grounded in accordance with the National Electrical Code to eliminate shock hazard.

- Electrical connection to the Radiant Heater is made through two openings tapped for 1/2" connector. Openings are in the top of the extruded heater housing, one near each end.
- Access to Radiant Heater terminals is obtained by removing the two screws in each of the terminal box covers.
- Wiring should be run in flexible or rigid metal conduit and must be installed in accordance with the requirements of the National Electric Code and such other local requirements as may be applicable.
- Wires supplying power to heating element terminals shall have insulation rated for 150°C minimum.

CAUTION

High Temperatures will oxidize copper. Use only nickel-plated copper wire for supplying power to heater. Do not use aluminum conductors.

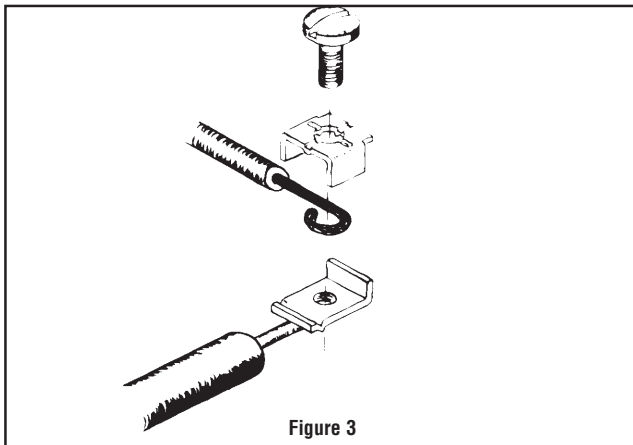
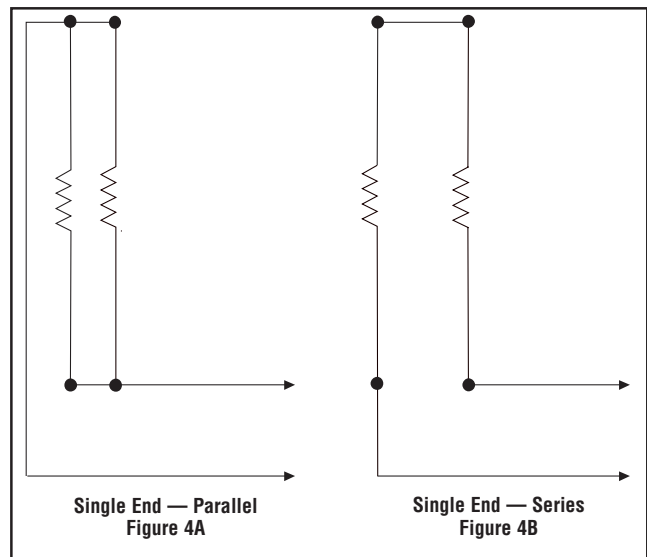

Figure 3

- A sufficient length of high temperature wire (not less than 12" should extend from heater terminals to a remote connection box whose location involves normal room temperatures thereby permitting use of normal electrical wiring to that point.
- Leave loop of wire in heater terminal box to allow for expansion movement of heating elements.
- Assemble terminal, screw, saddle clamp and wire as shown in Figure 3.
- Hold terminal with pliers and tighten the terminal screw securely with a screwdriver.
- Single End, Parallel Wiring** (Fig. 4A) Power wiring enters heater through either of the 1/2" tapped openings in heater housing. Wiring to opposite end is conveyed through wire-way provided behind integral reflector in housing extrusion. High temperature wire must be used; maximum wire diameter (over insulation) must not exceed 0.224". Each element must be rated at applied line voltage.
- Single End, Series Wiring** (Fig. 4B) Power wiring enters heater through either of the 1/2" tapped openings in heater housing. Heating element terminals at opposite end are wired in series. High temperature wiring must be used. Each element must be rated at 1/2 line voltage.

External series wiring of radiant heater assemblies is not practical when internal series connections can be made so easily.



Single End — Parallel
Figure 4A

Single End — Series
Figure 4B

WIRING (cont'd.)

11. Delta Connections — When heaters occur in multiples of three, they may be connected to, and balanced across, three-phase lines. The most commonly used connection is the delta connection illustrated in Fig. 5. Three phase Delta connections to minimize inductive effect in conduits are made per this diagram. The rule: run all 3 three-phase conductors in the same conduit as far as possible. For single-phase, run only two conductors and follow the same rule.

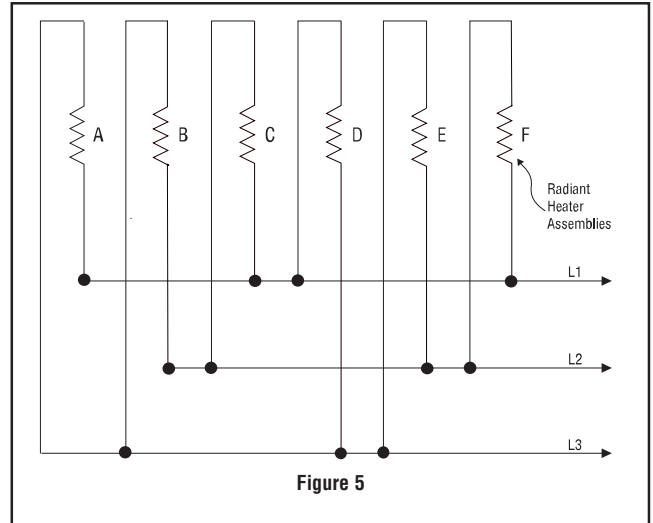

Figure 5

OPERATION

⚠ WARNING

FIRE/EXPOSITION HAZARD. This heater is not intended for use in hazardous atmospheres where flammable vapors, gases, liquids or other combustible atmospheres are present as defined in the National Electrical Code. Failure to comply can result in personal injury or property damage.

Before energizing this heater:

1. Be sure all electrical connections are tightly made. Hold terminal with pliers when tightening screw.
2. Be sure that all conductors are properly insulated.
3. Be sure that all element assemblies have been properly replaced, and that secondary insulation bushings have not been omitted.

A. Controlling Radiant Intensity

Standard Radiant heaters are built to operate at 40 watts per sq. inch on the element sheath. When it is desired to reduce radiant intensity, one or more of the following methods may be used.

1. **INPUT CONTROLLERS.** These motor-driven cycling devices can be used to vary heater output capacity from 4 to 100%. They are usually connected in holding coil circuit of controlling magnetic contactors. See Chromalox Radiant Heater Manual for further information regarding Input Controllers and Contactors.

2. SOLID STATE THYRISTOR POWER CONTROLLERS.

For best non-contact control of radiant heat, a Series #6 Chromalox Thyristor Power Controller with manual potentiometer setting is recommended. Truly proportional output of from 0 — 100% can be easily dialed-in to suit the particular product or process requirements. The Series #6 panels are pre-engineered, pre-packaged assemblies in an enclosure with circuit disconnect provided and ready for installation.

B. Maximum Ambient Temperatures

Chromalox Radiant Heaters are not recommended for applications in ambient temperatures exceeding 450°F. Higher ambient temperatures mean shorter heater life.

Maximum work temperature in a given time depends on several factors: Reflectivity of work, specific heat of work, mass of work, kW input and losses from oven, and time of exposure. As work temperature increases, the work loses heat by radiation and by convection to the surrounding ambient. Although it is a general principle of Radiant Heater application that work temperature conventionally exceeds ambient temperature, in cases where extremely high work temperatures are desired, it is necessary to enclose the heaters in order to increase the ambient. If evaporation of a liquid is desired as a result of increasing work temperature, it is necessary to provide ventilation air in order to carry away the evaporated liquid. Under carefully engineered circumstances, a maximum work temperature of 600°F may be attained.

MAINTENANCE

⚠ WARNING

ELECTRIC SHOCK HAZARD. Disconnect all power before installing or servicing heater. Failure to do so could result in personal injury or property damage. Heater must be installed or serviced by a qualified person in accordance with the National Electrical Code, NFPA 70.

A. To Remove Heating Element

1. Remove terminal cover screws and terminal cover.
2. Disconnect heating element from electrical leads at both ends.
3. Remove screws from porcelain terminal blocks.
4. Remove element support clips and secondary insulating bushings.
5. Lift out elements.

B. To Install Element

Observe instructions for removing elements and proceed in reverse fashion. Be sure to replace secondary insulating bushings.

C. Care of Reflectors

Reflectors should be cleaned periodically. A mild soap and water solution or fine cleaning powder is best although more drastic means may be required if reflectors are badly soiled by chemical or other deposits. The reflector is aluminum. DO NOT use alkali cleaners since alkalies will dull reflector. Mild non-alkaline cleaners, such as used for scouring kitchen sinks, may be used. Reflectors are replaceable and may be purchased from Chromalox.

- D. Because of the high temperatures involved, periodically check and retighten heater terminal connections. This practice will help to avoid "hot terminals" and the resulting damage to wire insulation.

- E. Because of the fire hazards resulting from a process malfunction, the related safety control used in the system should be periodically checked to ensure its proper operation.

RENEWAL PARTS IDENTIFICATION

PARTS COMMON TO ALL HEATERS

- ③ Terminal Cover 306-014405-001 (2)
- ④ Terminal Cover Clip 056-014401-002 (2)
- ⑤ End Plates 220-014462-001†
220-014462-002
- ⑧ Terminal Screw 248-046044-002 (4)

MISCELLANEOUS HARDWARE AND PARTS

- ⑨ Terminal Block (Bottom) 303-014317-001 (2)
- ⑩ Hexnut #8-32 200-049592-029 (2)
- ⑪ Terminal Block (Top) 303-014316-001 (2)
- ⑫ Screw #8-32 x 2-1/4" long 248-075512-390 (2)
- ⑬ Screw #8-32 x 3/8" long 248-075519-080 (4)
- ⑭ Screw #8-32 x 3/8" long 248-075512-053 (4)
- ⑯ Saddle Clamp 238-026539-001 (4)
- ⑰ Jumper Strap
(furnished with RADD-7604X10 only) 166-075230-030 (2)

HEATER MOUNTING CLAMP ASSEMBLY

See Figures 1, 2, 3, and 4, page 1.

For mounting heater with model numbers up to RADD 7000, use mounting clamp assembly part no. 168-013071-001. For mounting heaters above model number RADD 7000, use mounting clamp assembly part no. 168-013071-002.

† Indicates stamped end plate with voltage, wattage, etc.

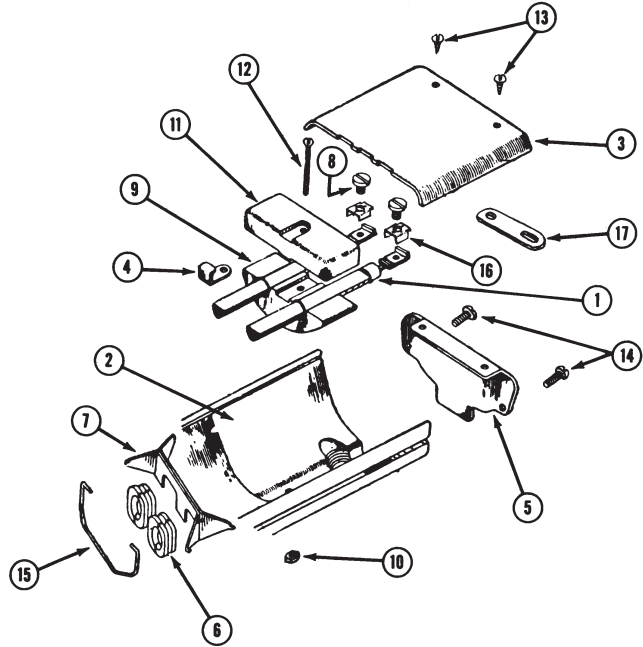

NOTE: Part numbers suffixed by a number in () indicates the quantity of the same part number used.

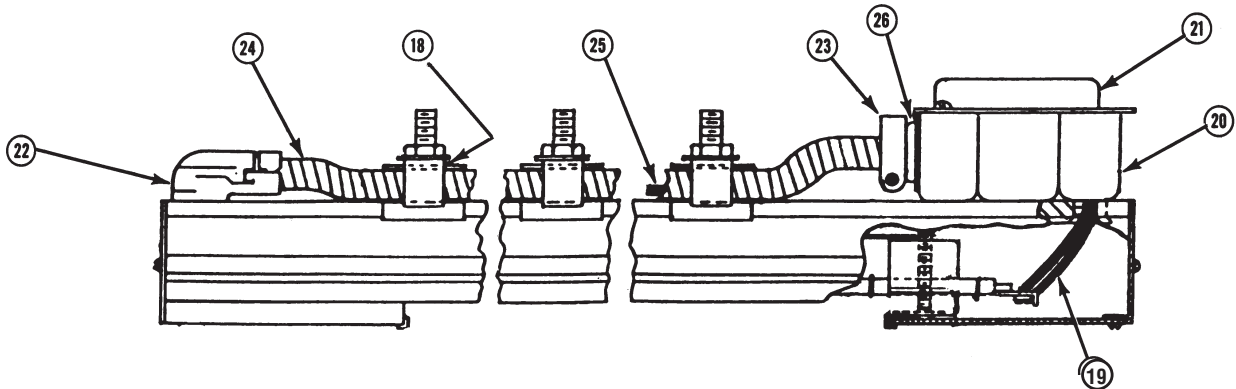

PARTS COMMON TO LONGER HEATERS

(RADD-7604X13, RADD-7604X9A, and RADD-7724X38)

- ⑱ Conduit Support Bracket 059-036915-001 (5)
- ⑲ #12 Gauge leadwire, 8"long 175-048142-171 (2)
- ⑳ 4" Conduit Box, Octagonal 025-036918-001
- ㉑ Conduit Box Cover 080-013160-004
- ㉒ 1/2" 90° Angle Box Connector 119-075455-002
- ㉓ 1/2" Box Connector 119-075454-005
- ㉔ 3/4 to 1/2" Reducing Washer 328-114681-001 (2)
- ㉕ Wiring Diagram 303-117271-001
(includes terminal block and jumper straps)

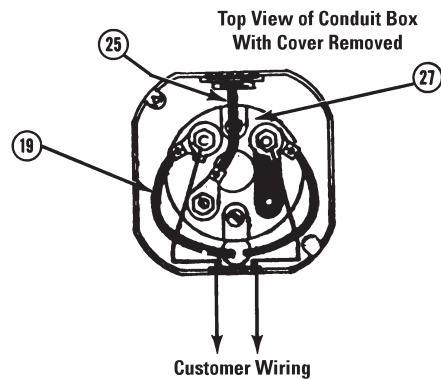

Model Number	㉔ 1/2" Flexible Steel Conduit	㉕ #10 Gauge Leadwire
RADD-7604X13	069-024328-011	175-048141-078
RADD-7604X9A	069-024328-010	175-048141-077
RADD-7724X38	069-024328-012	175-048141-079

RENEWAL PARTS IDENTIFICATION

Model Number	Volts	Watts per Element	① Element Model Number	② Reflector Sheet	③ Terminal Cover	⑥ Insulation Bushing	⑦ Element Support Clip	⑮ Bushing Retaining Clip
RADD-2164	120 208 240 275	800	RTU-2083A-120V (2) RTU-2083AV-208V (2) RTU-2083A-240V (2) RTU-2083AV-275V (2)	234-013411-011	306-014405-001 (2)	_____	_____	_____
RADD-3224	120 208 240 275	1100	RTU-3113A-120V (2) RTU-3113AV-208V (2) RTU-3113A-240V (2) RTU-3113AV-275V (2)	234-013411-012	306-014405-001 (2)	_____	_____	_____
RADD-3264	208 240 275 480	1300	RTU-3133AV-208V (2) RTU-3133A-240V (2) RTU-3133AV-275V (2) RTU-3133A-480V (2)	234-013411-013 234-013411-013 234-013411-013 234-013411-013	306-014405-001 (2)	_____	_____	_____
RADD-4364	208 240 275 480	1800	RTU-4183AV-208V (2) RTU-4183A-240V (2) RTU-4183AV-275V (2) RTU-4183A-480V (2)	234-013411-014	306-014405-001 (2)	032-013454-001 (4)	059-014304-002	059-017175-001
RADD-5434	208 240 275 480	2150	RTU-5213AV-208V (2) RTU-5213A-240V (2) RTU-5213AV-275V (2) RTU-5213A-480V (2)	234-013411-015 234-013411-015 234-013411-015 234-013411-015	306-014405-001 (2)	032-013454-001 (8) 032-013454-001 (8) 032-013454-001 (8) 032-013454-001 (8)	059-014304-002 (2) 059-014304-002 (2) 059-014304-002 (2) 059-014304-002 (2)	059-017175-001 (2) 059-017175-001 (2) 059-017175-001 (2) 059-017175-001 (2)
RADD-5504	208 240 275 480	2500	RTU-5253AV-208V (2) RTU-5253A-240V (2) RTU-5253AV-275V (2) RTU-5253A-480V (2)	234-013411-016	306-014405-001 (2)	032-013454-001 (12)	059-014304-002 (3)	059-017175-001 (3)
RADD-6544	208 240 275 480	2700	RTU-6273AV-208V (2) RTU-6273A-240V (2) RTU-6273AV-275V (2) RTU-6273A-480V (2)	234-013411-017 234-013411-017 234-013411-017 234-013411-017	306-014405-001 (2)	032-013454-001 (12) 032-013454-001 (12) 032-013454-001 (12) 032-013454-001 (12)	059-014304-002 (3) 059-014304-002 (3) 059-014304-002 (3) 059-014304-002 (3)	059-017175-001 (3) 059-017175-001 (3) 059-017175-001 (3) 059-017175-001 (3)
RADD-6604	208 240 275 480	3000	RTU-6303AV-208V (2) RTU-6303A-240V (2) RTU-6303AV-275V (2) RTU-6303A-480V (2)	234-013411-018	306-014405-001 (2)	032-013454-001 (16)	059-014304-002 (4)	059-017175-001 (4)
RADD-7674	208 240 275 480	3350	RTU-7333AV-208V (2) RTU-7333A-240V (2) RTU-7333AV-275V (2) RTU-7333A-480V (2)	234-013411-006* and 234-013411-015*	306-014405-001 (2)	032-013454-001 (16) 032-013454-001 (16) 032-013454-001 (16) 032-013454-001 (16)	059-014304-002 (4) 059-014304-002 (4) 059-014304-002 (4) 059-014304-002 (4)	059-017175-001 (4) 059-017175-001 (4) 059-017175-001 (4) 059-017175-001 (4)
RADD-7724	208 240 275 480	3600	RTU-7363AV-208V (2) RTU-7363A-240V (2) RTU-7363AV-275V (2) RTU-7363A-480V (2)	234-013411-004* and 234-013411-012*	306-014405-001 (2)	032-013454-001 (20)	059-014304-002 (5)	059-017175-001 (5)
RADD-8904	208 240 275 480	4500	RTU-8453AV-208V (2) RTU-8453A-240V (2) RTU-8453AV-275V (2) RTU-8453A-480V (2)	234-013411-049 (2) 234-013411-049 (2) 234-013411-049 (2) 234-013411-049 (2)	306-014405-001 (2)	032-013454-001 (20) 032-013454-001 (20) 032-013454-001 (20) 032-013454-001 (20)	059-014304-002 (5) 059-014304-002 (5) 059-014304-002 (5) 059-014304-002 (5)	059-017175-001 (5) 059-017175-001 (5) 059-017175-001 (5) 059-017175-001 (5)
RADD-7604X10	240	4000	RTU-7303AX10-240V (2)	234-013411-016 (2)	306-014405-001 (2)	023-013454-001 (24)	059-014304-002 (8)	059-017175-001 (6)
RADD-7604X13	240 or 480	5000	RTU-7303AX13-240 (2)**	243-013411-058 (3)	306-014405-002 (2)	032-013454-001 (23)	059-014304-002 (8)	059-017175-001 (9)
RADD-7604X9A	240 or 480	5500	RTU-7303AX9A-240 (2)**	234-013411-057 (4)	306-036916-003 (2)	032-013454-001 (32)	059-014304-002 (8)	059-017175-001 (10)
RADD-7724X38	240 or 480	6500	RTU-7363AX38-240 (2)**	234-013411-059 (4)	306-036916-003 (2)	032-013454-001 (32)	059-014304-002 (8)	059-017175-001 (11)

*For ease of installation, these reflectors shipped in two pieces (one each of part numbers listed).

**Shipped as 480V. Convert to 240V by changing jumpers. See WIRING Section on page 2.

NOTES:

1. Part numbers suffixed by a number in () indicates the quantity of the same part number used.
2. Interlocking connector parts have been discontinued.

Limited Warranty:

Please refer to the Chromalox limited warranty applicable to this product at <http://www.chromalox.com/customer-service/policies/termsofsale.aspx>.

Chromalox[®]
PRECISION HEAT AND CONTROL

2150 N. RULON WHITE BLVD., OGDEN, UT 84404
Phone: 1-800-368-2493 www.chromalox.com